

Chromalox®

Installation and OPERATION INSTRUCTIONS

SERVICE REFERENCE	
DIVISION 4	SECTION WCRT
SALES REFERENCE (Supersedes PK471-3)	PK471-4
161-562767-001	
DATE	DECEMBER, 1998



UL LISTED

Figure 1

WCRT Weather-Corrosion Resistant Room Thermostat

Specifications – Table A

Model	Temperature Range (°F)	Switch Action	Description	Maximum Rating		
				120 Vac	240 Vac	277 Vac
WCRT-100	40-100	SPDT	Full Load Inductive	16.0A	12.0A	10.0A
			Locked Rotor	80.0A	60.0A	55.0A
			Non-Inductive	25.0A	25.0A	22.0A
			Pilot Duty	125VA	125VA	125VA

GENERAL

Type WCRT thermostats are intended for use in harsh environments. They tolerate continuous spraying with water, high humidity, airborne contaminants and moderately corrosive conditions. The nickel plated sensing bulb is attached directly to the bottom of the case where it is shielded from damage or accumulations of insulating particles. The molded Noryl case is sealed at the cover with a neoprene gasket and the adjusting knob opening is closed with a lubricated O ring. Underwriters Laboratories has tested the WCRT and found it meets the requirement for NEMA 4X areas.

High levels of accuracy and sensitivity, 2½° differential, are provided by the WCRT. Switching is done by heavy duty, precision, single stage, SPDT line voltage snap action switch. Setting is accomplished by rotating the adjusting knob. The dial face is printed with large, contrasting numbers and letters on a lustrous background for good visibility. Color coding clearly identifies the function of each conductor.

Applications – Automatically controls room temperature by turning electric air heaters on and off. Can be used to control the air heaters directly, within thermostat rating. For higher ratings use thermostat with magnetic contactor. Place thermostat on inside wall, away from undue heating or cooling influences, about 4 feet above the floor.

NOTICE: Type WCRT thermostats are designed for temperature control service only. Because they do not fail safe, they should not be used for temperature limiting duty.

WARNING: Users should install adequate back-up controls and safety devices with their electric heating equipment. Where the consequences of failure may be severe, back-up controls are essential. Although the safety of the installation is the responsibility of the user, Chromalox will be glad to make equipment recommendations.

Principle of Operation – Control action of these thermostats is provided through the principle of liquid volume change. With a variation in temperature, the liquid in the sensing element expands or contracts, causing a bellows to actuate the switching mechanism.

WARNING: Not for use in hazardous environments as described in National Electrical Code. Failure to comply can result in explosion or fire.

LO Setting is positive open (black to red) for heating loads and is positive closed (black to blue) for cooling loads.

Note: It is **not** recommended to switch systems directly from heating to cooling and vice versa.

MOUNTING

Note: Do not mount control where it will be subject to vibration or shock. Do not mount adjacent to a large magnetic contactor, as vibration and shock will cause thermostat to interact erratically – resulting in chattering of the contactor.

- The proper location of a heavy duty room thermostat is important to assure good performance.
 - Locate where air circulates freely.
 - Never install on or near outside wall.
 - Keep away from windows or doors.
 - Do not locate too close to strong light or other false source of heat, such as sunlight, steam lines, etc.
 - If electrical conduit leads into cooler or warmer room, plug up space around wires in the conduit with rock wool.
- Use sheet metal or wood screws through the four $\frac{1}{4}$ " diameter mounting holes in the housing to mount control. (See Figure 2.)
- WARNING: Any deformations of bulb or capillary that result in leakage of fluid from control renders control inoperative.**

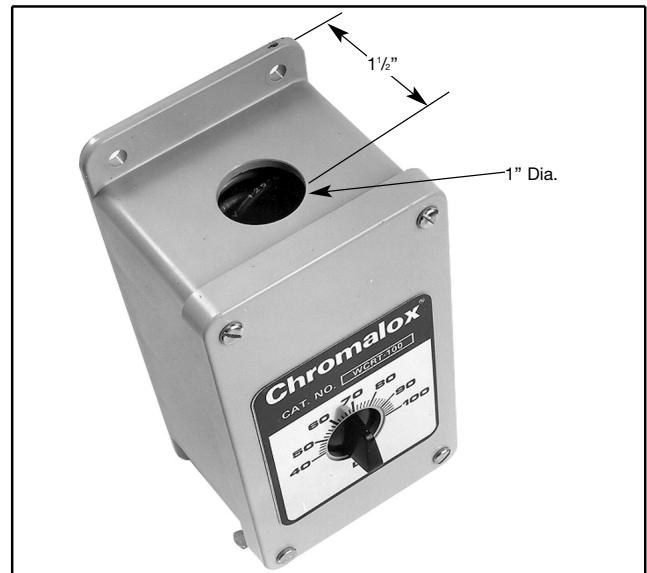

Dimensions

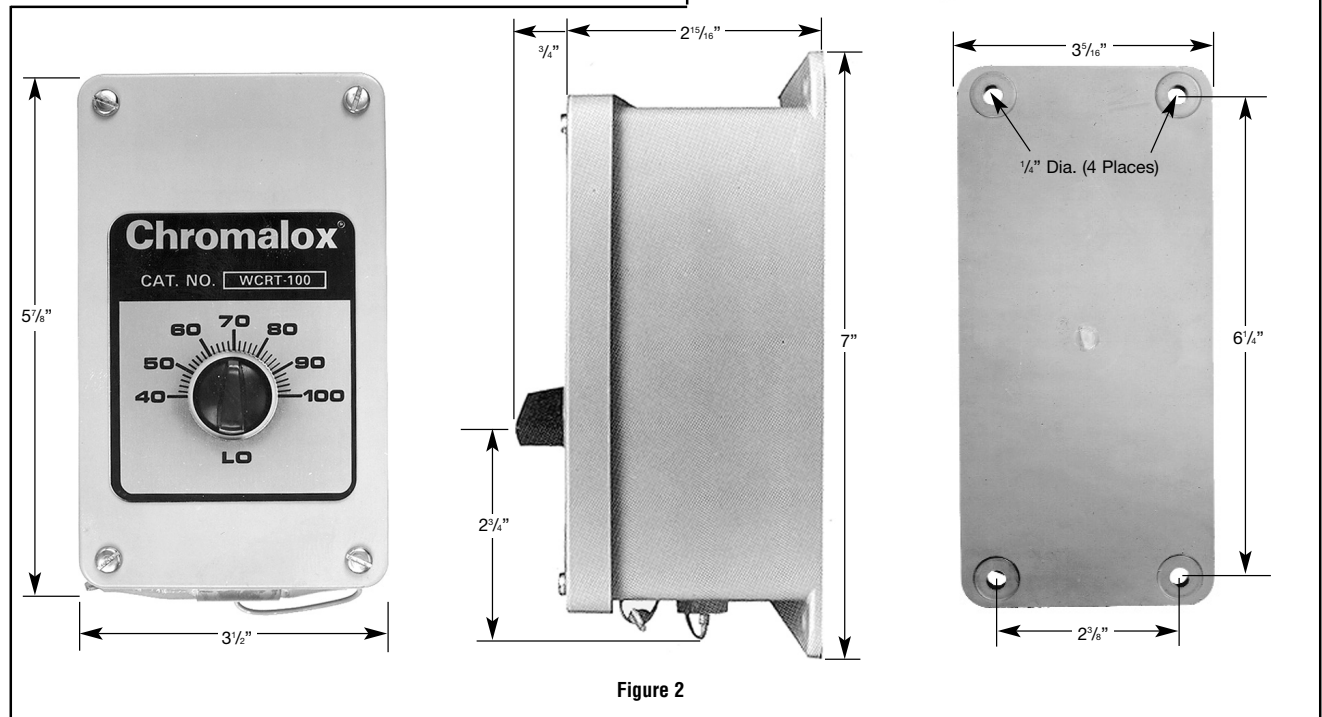

Figure 2

WIRING

WARNING: Hazard of Electrical Shock. Disconnect all power before wiring or servicing this control.

- Electric wiring must be installed in accordance with the National Electrical Code and with local codes by a qualified person. **WARNING:** Use copper conductors only.
- Entrance for wiring is provided by one 1-inch conduit hole in top of housing. Wiring to control housing should be in moisture-resistant conduit.
- Remove cover by removing four screws (see Figures 3 and 4).
- The Chromalox type WCRT thermostat has an enclosed SPDT switch and may be wired to open on temperature rise (black to red) or to close on temperature rise (black to blue). (See Figure 5.)
- Connect wires according to wiring diagrams (Figures 6 and 7).

Note: Electrical connections should be made with generous loops of wire – approximately 6" per lead.

- Replace cover and cover screws. Tighten screws to 4-5 inch pounds torque.
- Note:** If load amperage or voltage rating exceeds switch rating and for 3 phase loads, a contactor must be used. Contactor and wiring to be supplied by customer (see Figure 7).

WARNING: Non-metallic enclosure requires the use of ground type hub and a jumper wire for grounding the thermostat.

NOTICE: Thermostat is UL Listed for NEMA-4X areas. For it to retain this listing the sealed conduit hub must also be so listed. Example Myers Nos. ST-1, ST-2, STR-1, STR-2 or engineering equivalent.

WIRING



Figure 3

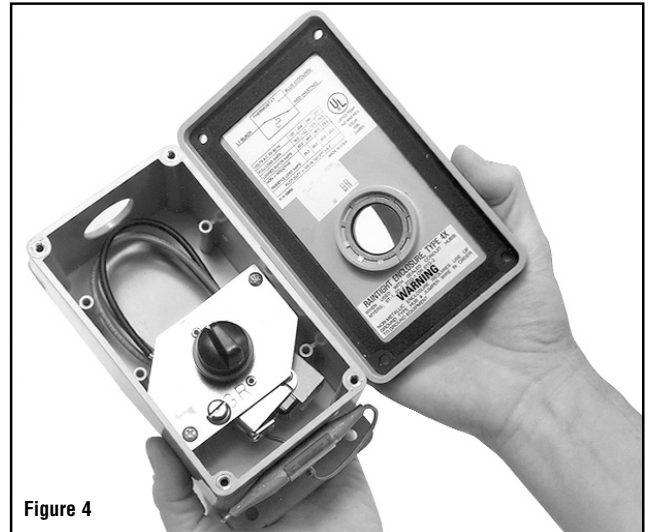

Figure 4

WIRING DIAGRAMS

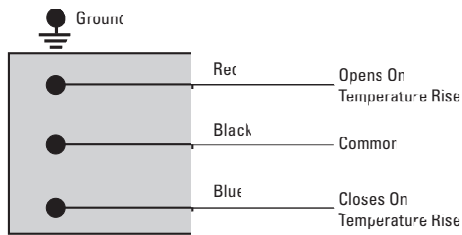
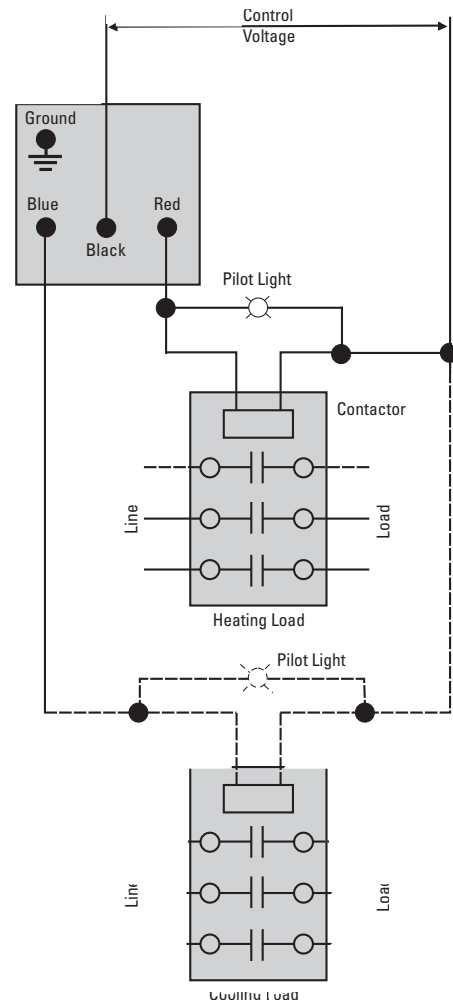
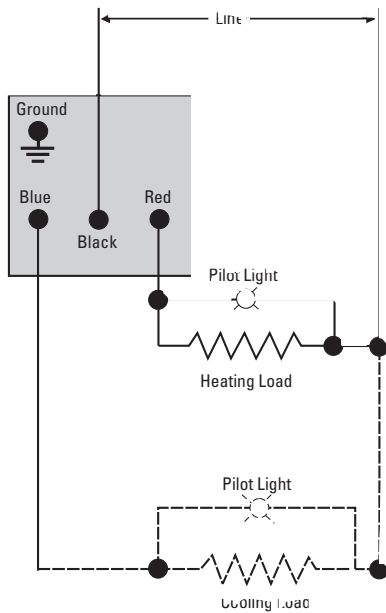

Figure 5



Three Phase and Single Phase When Load Exceeds Thermostat Rating.

Figure 7



Single Phase When Load or Voltage Does Not Exceed Thermostat Rating.

Figure 6

TESTING AND OPERATION

After installation and wiring, to check the operation of heating systems:

1. Disconnect power.
2. Place the heat/cool selector switch, if applicable, in the heat position.
3. Adjust the setpoint ten or more degrees below the temperature of the controlled space.
4. Restore power.
5. Slowly adjust the setpoint upward. When the setpoint reaches the approximate temperature of the controlled space, the heating equipment should start.

To check the operation of the cooling systems:

1. Disconnect power.
2. Place the heat/cool selector switch, if applicable, in the cool position.
3. Adjust the setpoint ten or more degrees above the temperature of the controlled space.
4. Restore power.
5. Slowly adjust the setpoint downward. When the setpoint approximates the temperature of the controlled space, the cooling equipment should start.

Limited Warranty:

Please refer to the Chromalox limited warranty applicable to this product at <http://www.chromalox.com/customer-service/policies/termsofsale.aspx>.

Chromalox[®]
PRECISION HEAT AND CONTROL

1347 HEIL QUAKER BLVD., LAVERGNE, TN 37086
Phone: (615) 793-3900 www.chromalox.com