

## Installation Instructions

# USL Signal Light Kit

for Self-Regulating Constant Wattage Heating Cables



PJ937-1  
161-562581-032  
May, 2021

## USL Signal Light Kit

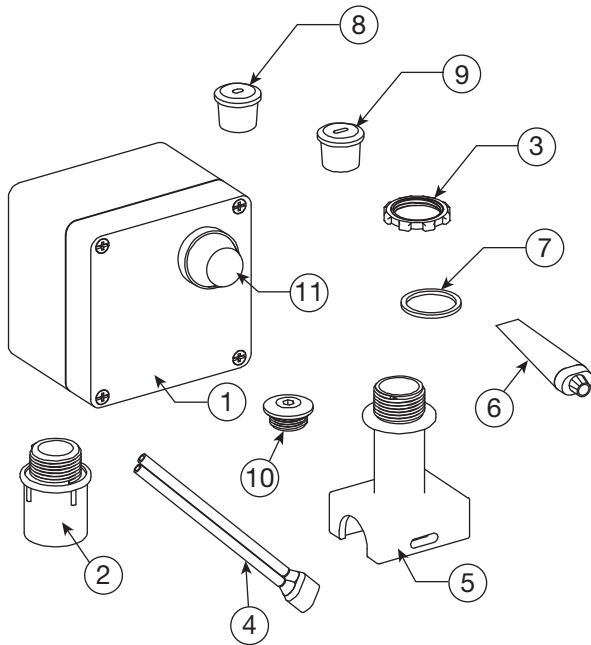

Item	Qty	Description
1	1	Junction box
2	1	Compression fitting
3	1	Locknut
4	1	Silicone termination boot
5	1	Pipe standoff
6	1	RTV
7	1	O-Ring
8	1	Self-regulating cable grommet (Black)
9	1	Constant wattage cable grommet (Orange)
10	1	Conduit Plug
11	1	Signal Light

### General

The USL signal light kit is used for electrical termination of self regulating and constant wattage cables. Each kit contains the terminations needed to make all electrical connections.

### Certifications & Approvals

IP66 NEMA/Type 4X -60°C < Ta < +55°C  
Ordinary Areas



### Installation

#### **⚠ WARNING**

**HAZARD OF ELECTRIC SHOCK. Disconnect all power before starting. All installations must be effectively grounded in accordance with the National Electrical Code to eliminate shock hazard.**

#### **⚠ WARNING**

**Turn off power before removing junction box cover at all times.**

#### **⚠ WARNING**

**Users should install adequate controls and safety devices with their electric heating equipment. Where the consequences of failure may be severe, back-up controls are essential. Although the safety of the installation is responsibility of the user, Chromalox will be glad to assist in making equipment recommendations.**

**Braid only cable instructions for SRL-C, SRM/E-C CWM-C cable special instructions denoted by \***

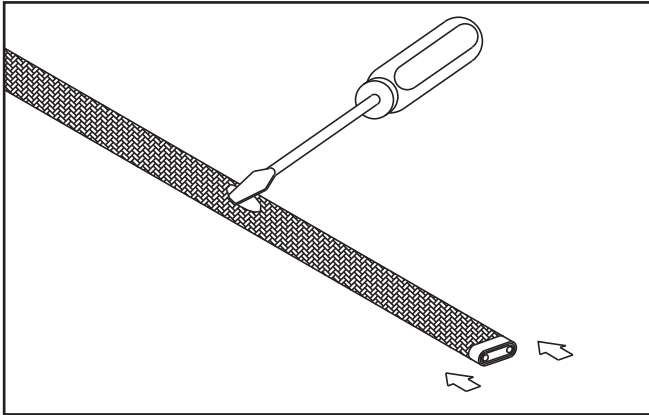

1. Push braiding back from the end of the cable. 11" from cable end create a bulge. At the bulge, separate the braid to make an opening.

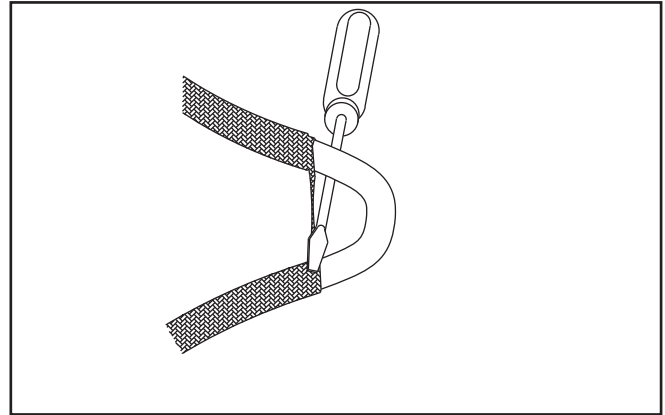

2. While bending the heating cable, work the cable through the braid opening. Pull the braid tight..

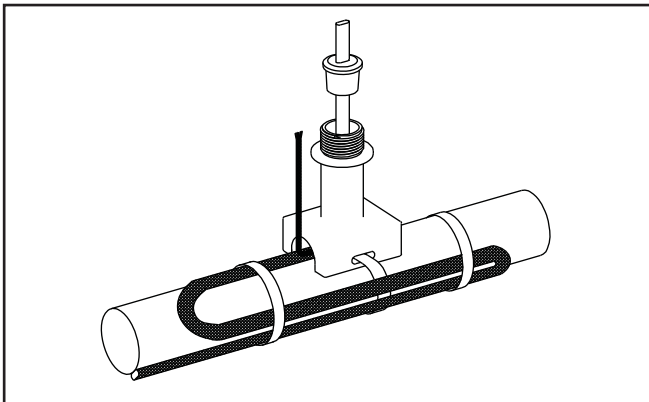

3. Insert cable through pipe standoff and grommet as shown. Leave braid outside of pipe standoff for future connection to ground. Attach standoff.

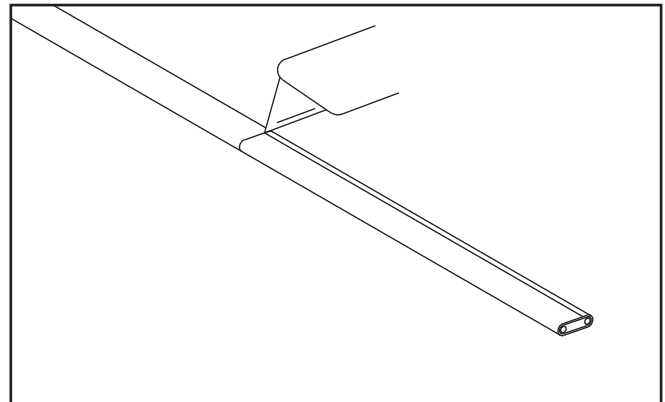

4. Score the inner insulation 7" from the end. Lightly cut the inner jacket up the center to end of heating cable and remove the inner jacket from the cable.

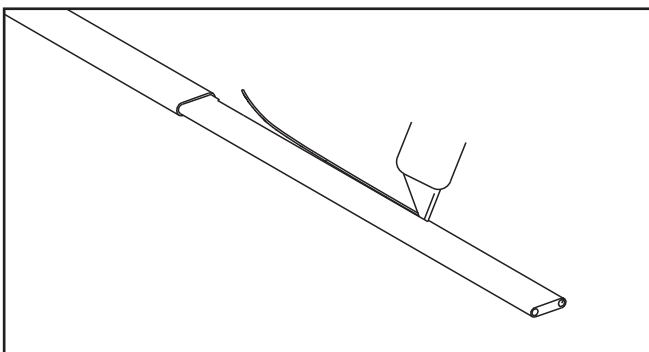

5. Shave the core material from the outside of each bus wire.

\*Skip this step if using CWM-C constant wattage cable.

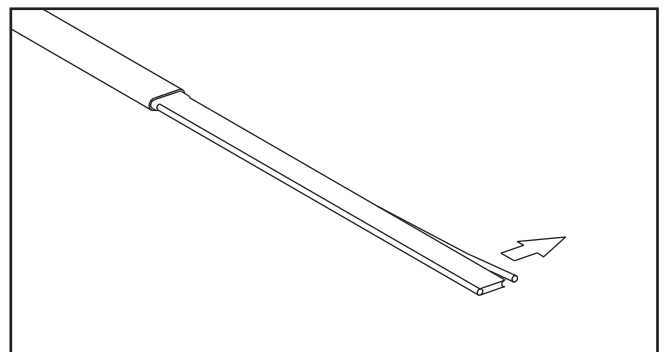

6. Starting at the end of the heating cable, using needle nose pliers or a knife pull each bus wire away from the core material.

\*Separate CWM-C leads and strip 1/4" from each leadwire.

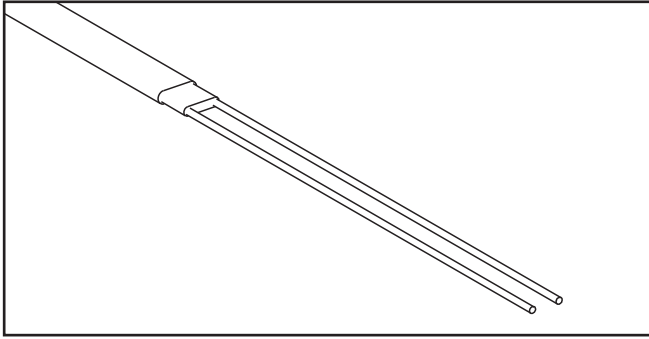

7. Remove the exposed core material and cut 1/4" off the end of each bus wire. \*Skip this step if using CWM-C constant wattage cable.

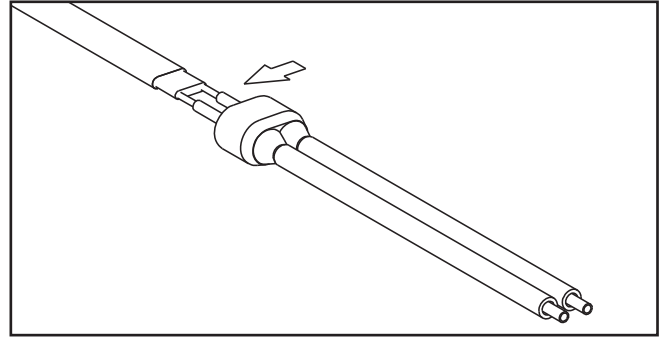

8. Liberally apply RTV over the exposed matrix and leads. Push the rubber boot over the heating cable. Trim lead ends as needed.

\*Boot is not needed when using CWM-C constant wattage cable.

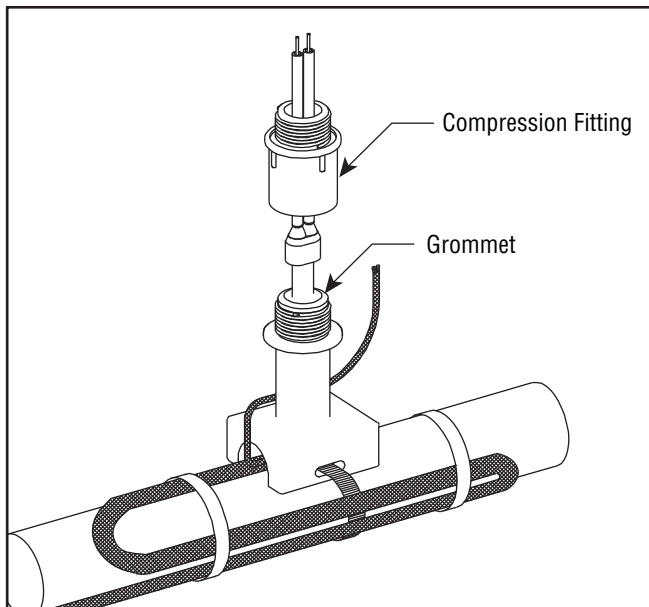

9. Slide compression fitting over cable. Grommet should be placed inside pipe standoff. Termination boot should be spaced 1/2" from sealing grommet. Tighten compression fitting until it bottoms out against pipe standoff.

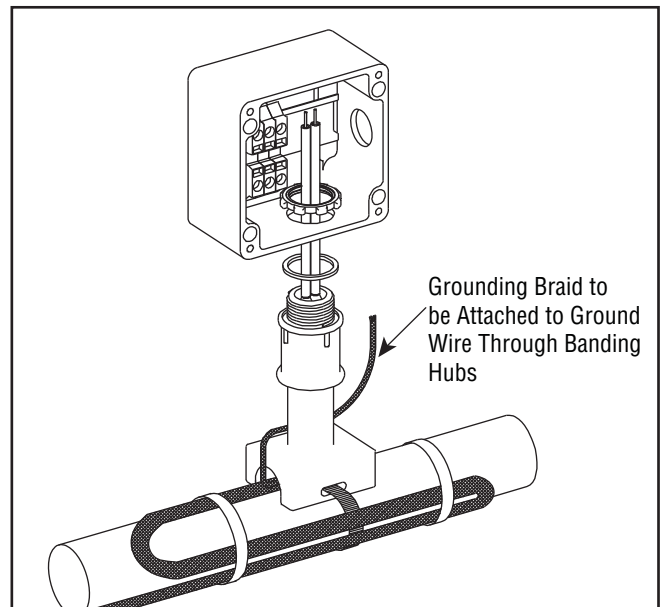

10. Assemble junction box to compression fitting as shown. Tighten locknut until the junction box bottoms out against the lip of the compression fitting.

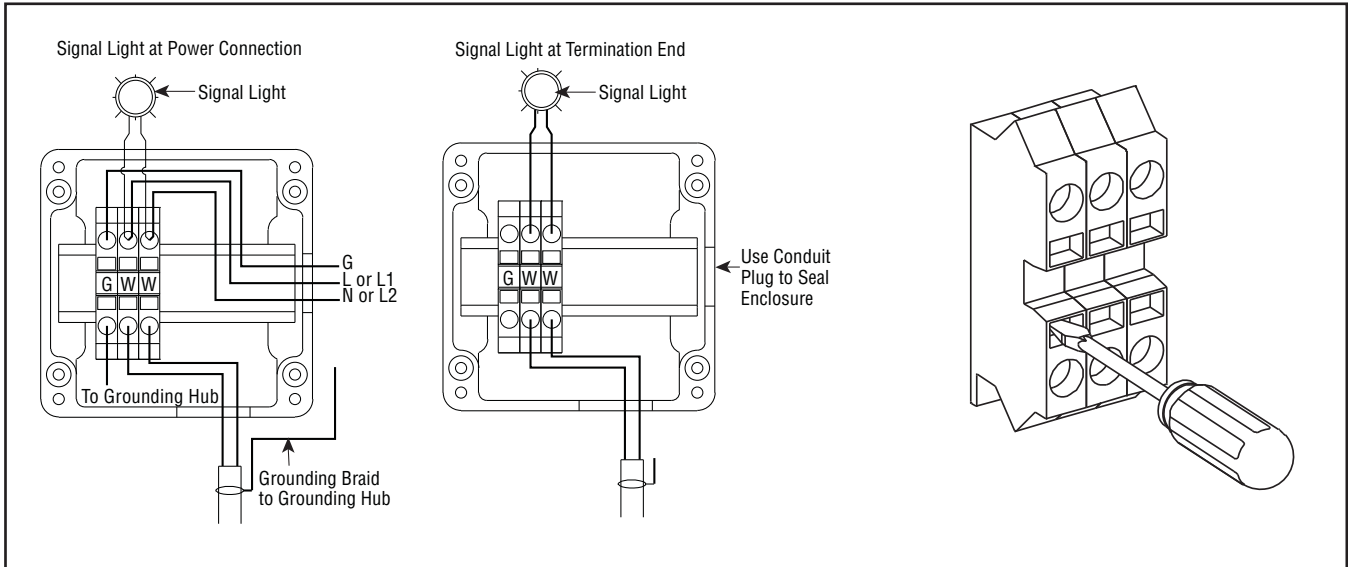

11. Attach conduit hub (Chromalox CCH-2 or equivalent not included). Use a flat head screwdriver to release the terminal spring clamps and insert cable leads. Supply power electrical connections should be brought to terminal as shown below. Attach junction box cover to seal enclosure.

**Overjacketed cable instructions for SRL-CR, SRL-CT, SRM/E-CT, CWM-CT cable instructions denoted by \***

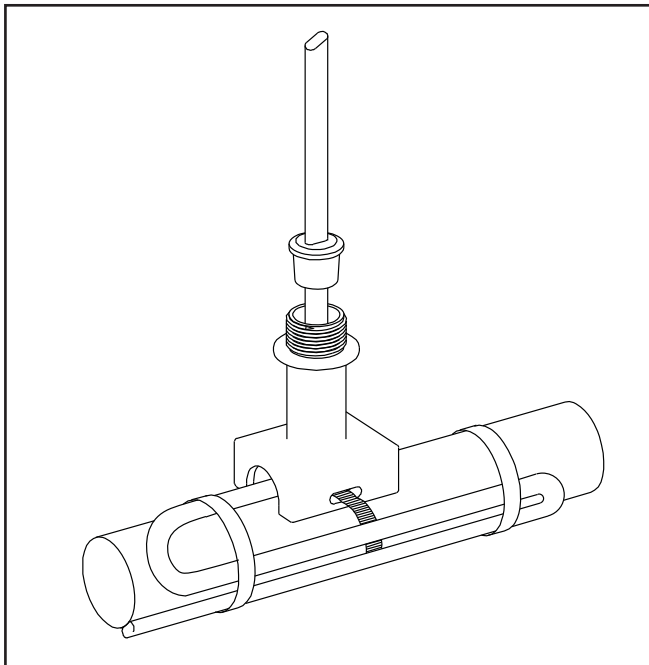

1. Insert heating cable through pipe standoff and grommet as shown. 8" of cable should extend past the grommet. Strap pipe standoff to pipe with pipe strap (Chromalox type PS not included) and attach extra cable to pipe as appropriate. For pipes smaller than 1-1/2" diameter a small pipe adapter (Chromalox model SPA not included) is required.

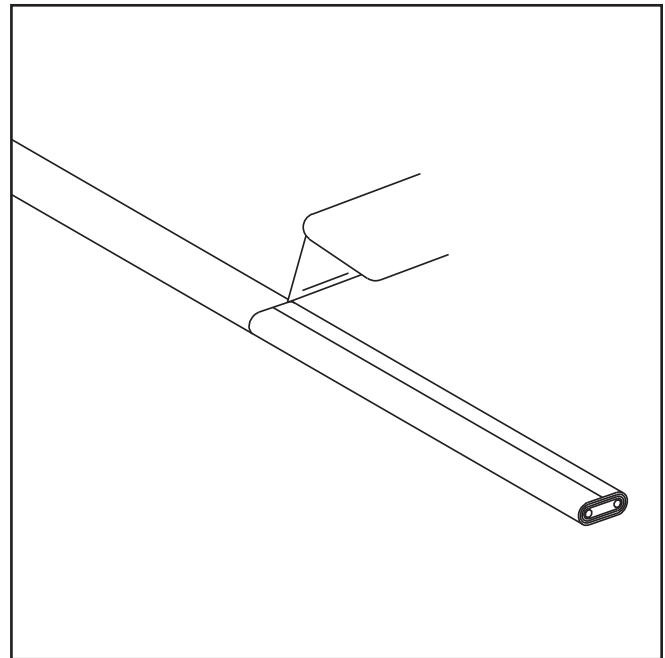

2. Score the outer insulation 7" from the end of the cable. Lightly cut the outer jacket up the center to the end of heating cable and remove the outer jacket from the cable. **WARNING: DO NOT CUT METAL BRAID.**

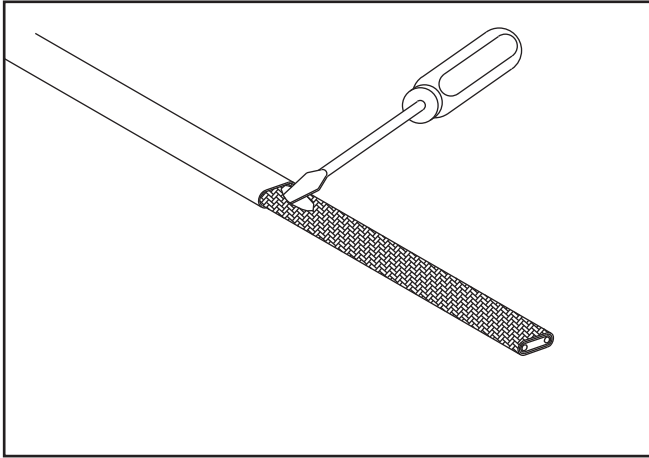

3. Move braid back toward the overjacket, creating a bulge. At the bulge, separate the braid to make an opening.

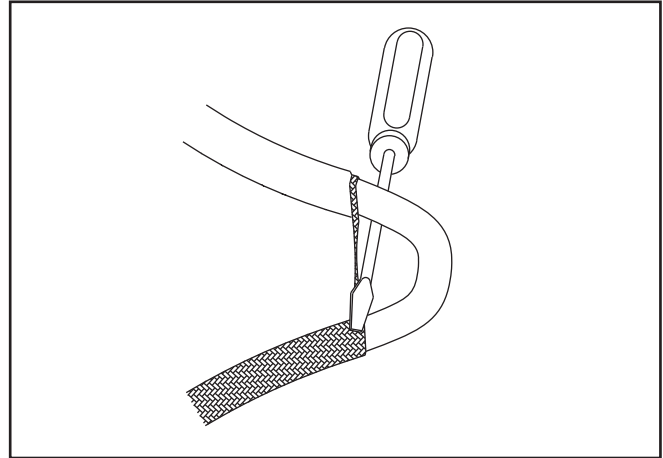

4. While bending the heating cable, work the cable through the braid opening. Pull the braid tight.

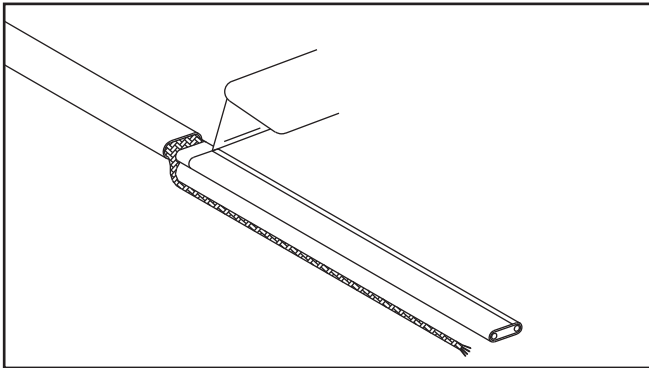

5. Score the inner insulation 6" from the end. Lightly cut the inner jacket up the center to end of heating cable and remove the inner jacket from the cable.

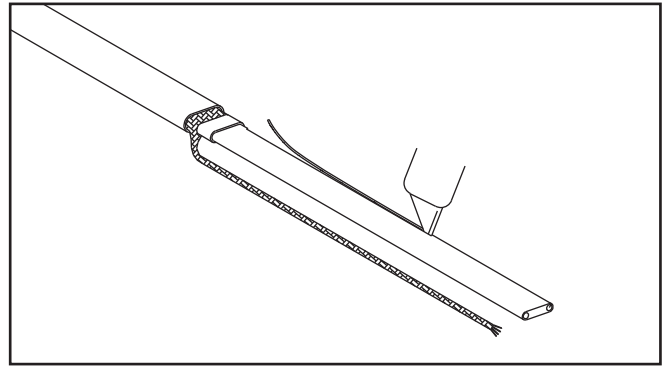

6. Shave the core material from the outside of each bus wire.  
\*Skip this step if using CWM-C constant wattage cable.

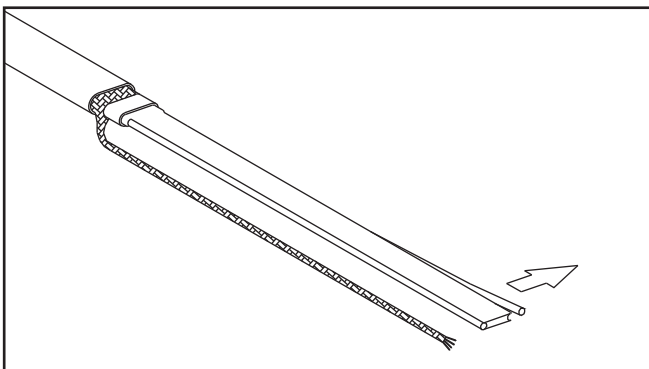

7. Starting at the end of the heating cable, using needle nose pliers or a knife pull each bus wire away from the core material.

\*Separate CWM-C leads and strip 1/4" from each leadwire.

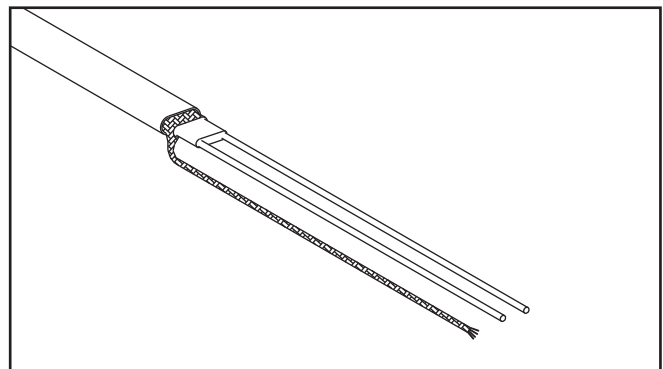

8. Remove the exposed core material and cut 1/4" of the end of each bus wire. \*Skip this step if using CWM-C constant wattage cable.

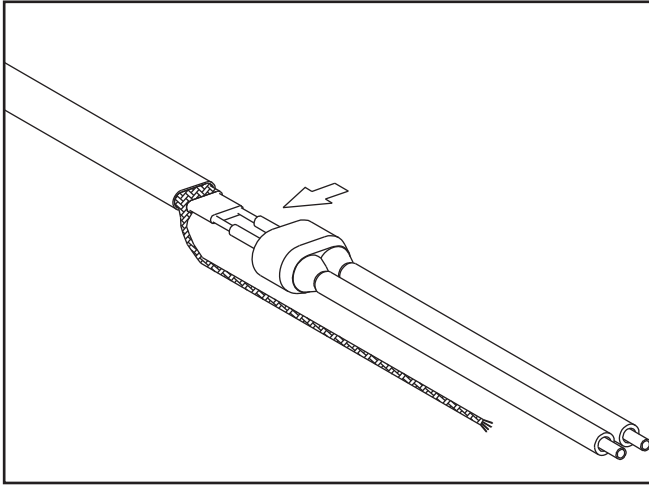

9. Liberally apply RTV over the exposed matrix and leads. Push the rubber boot over the heating cable. Trim lead ends as needed.

\*Boot is not needed when using CWM-C constant wattage cable.

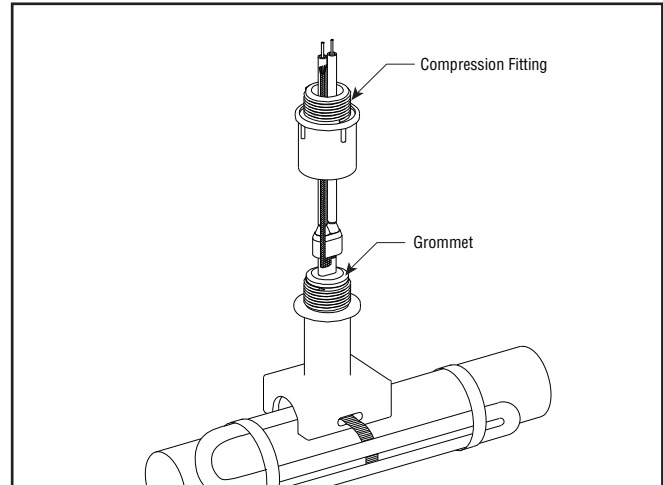

10. Slide compression fitting over cable. Grommet should be placed inside pipe standoff. Termination boot should be spaced 1/2" from sealing grommet.

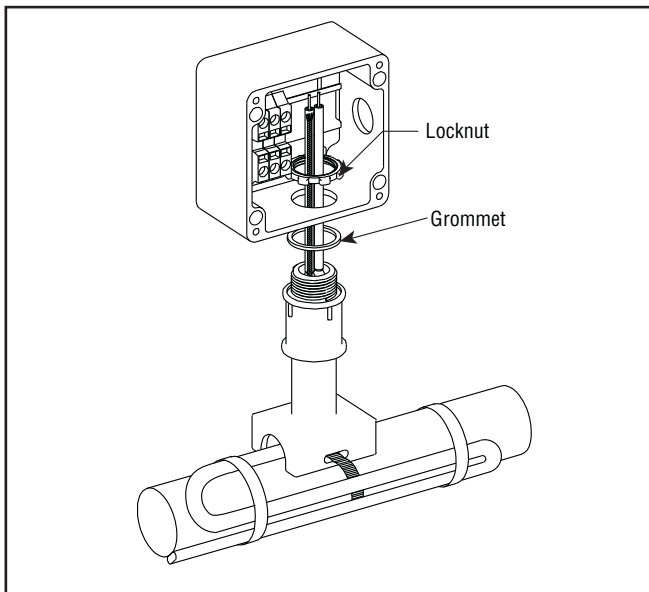

11. Assemble junction box to compression fitting as shown. Tighten locknut until the junction box bottoms out against the lip of the compression fitting.

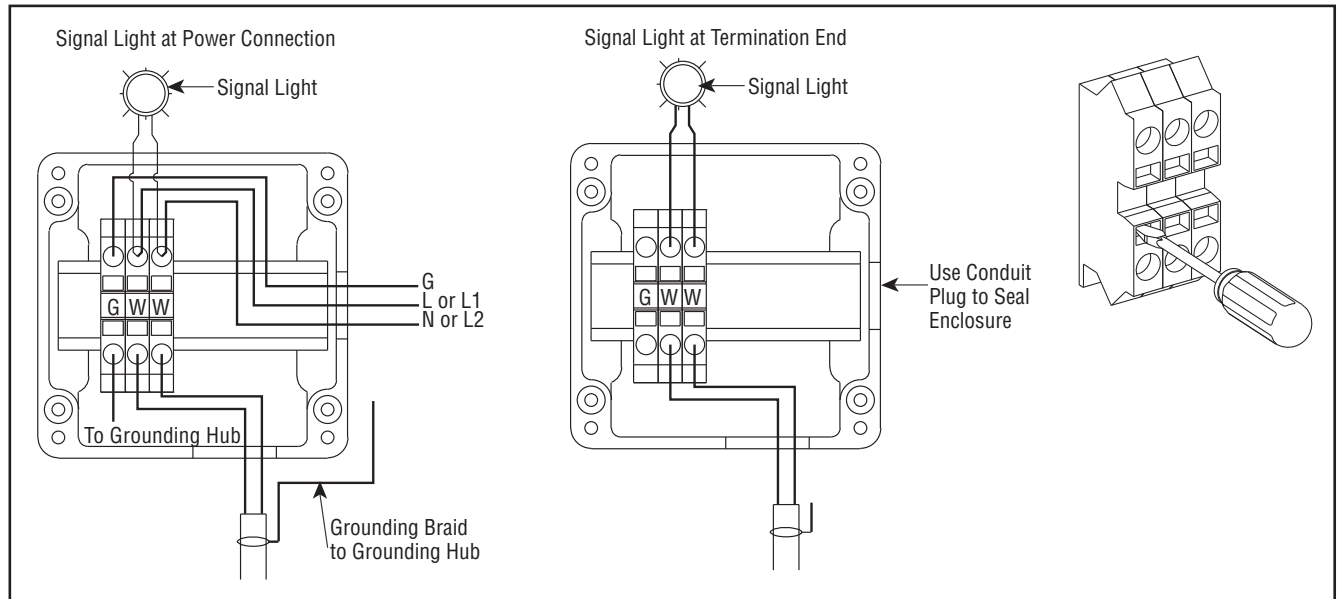

12. Attach conduit hub (Chromalox CCH-2 or equivalent not included). Use a flat head screwdriver to release the terminal spring clamps and insert cable leads and grounding braid. Supply power electrical connections should be brought to terminal as shown. Attach junction box cover to seal enclosure.

**Limited Warranty:**

Please refer to the Chromalox limited warranty applicable to this product at <http://www.chromalox.com/customer-service/policies/termsforsale.aspx>.