

Installation Instructions

RTST Splice & Tee Connection Kit

for Self-Regulating and
Constant Wattage Heating Cable

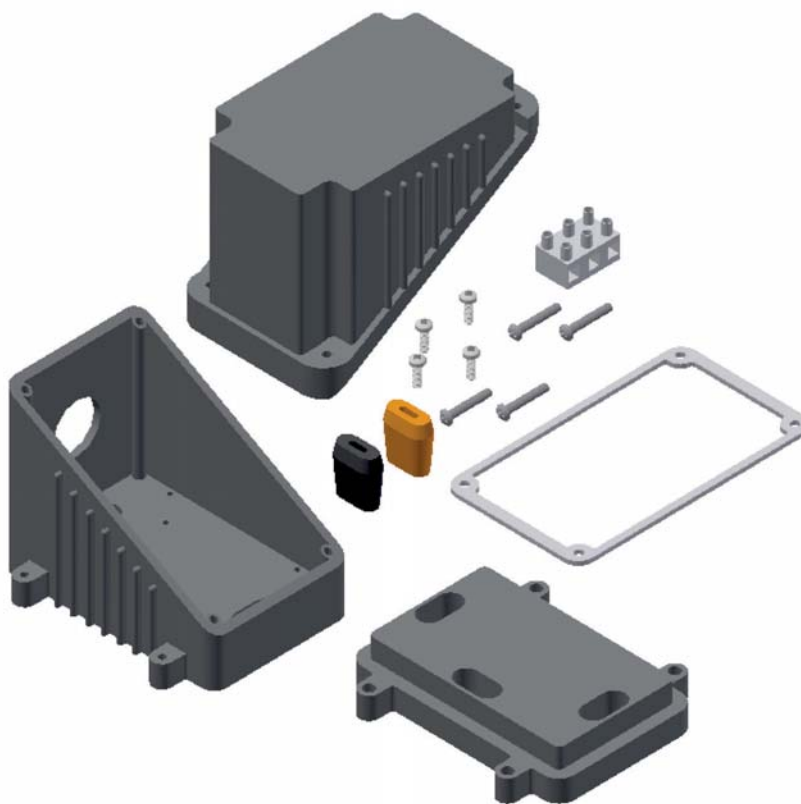

PJ452-12
161-562763-001
April 2020

RTST Splice & Tee Connection Kit

Self-Regulating & Constant Wattage Heating Cable

Installation Instructions

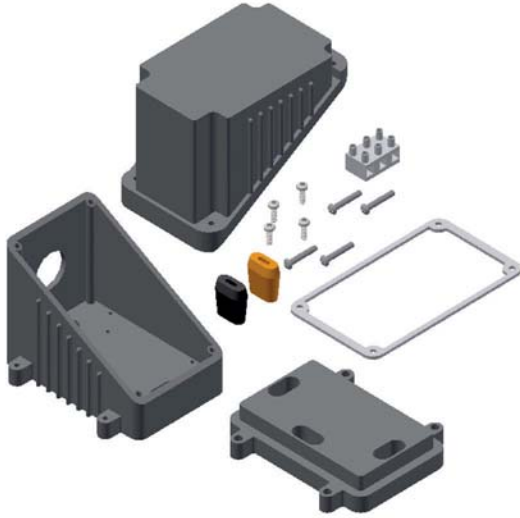

Qty	Description
1	Junction Box Base
1	Junction Box Lid
1	Junction Box
1	Three Position Terminal Block
1	Cover Gasket
1	Black Grommet
3	Orange Grommet
1	Terminal Block Screw
3	Uninsulated Barrel Connector
4	Cover Screws, 5/8" Long
4	Box Screws, 1" Long

General

These kits are designed to provide temperature control as well as termination for one run of Chromalox Self-regulating or Constant Wattage Heating Cable.

Each kit contains enough material to connect one cable. One additional self-regulating cable can be connected; an extra grommet is required.

Certifications/Approvals



Tools Required for Kit Installation



Order Separately

Pipe Straps

Pipe Strap: 1/2" to 3/4" pipes Pipe Strap: 2-1/2" to 9" pipes
 Pipe Strap: 1" to 3-1/2" pipes Pipe Strap: 9" to 19.5" pipes



Caution Label CL-1 Fiberglass Tape FT-3



Actual Kit Dimensions

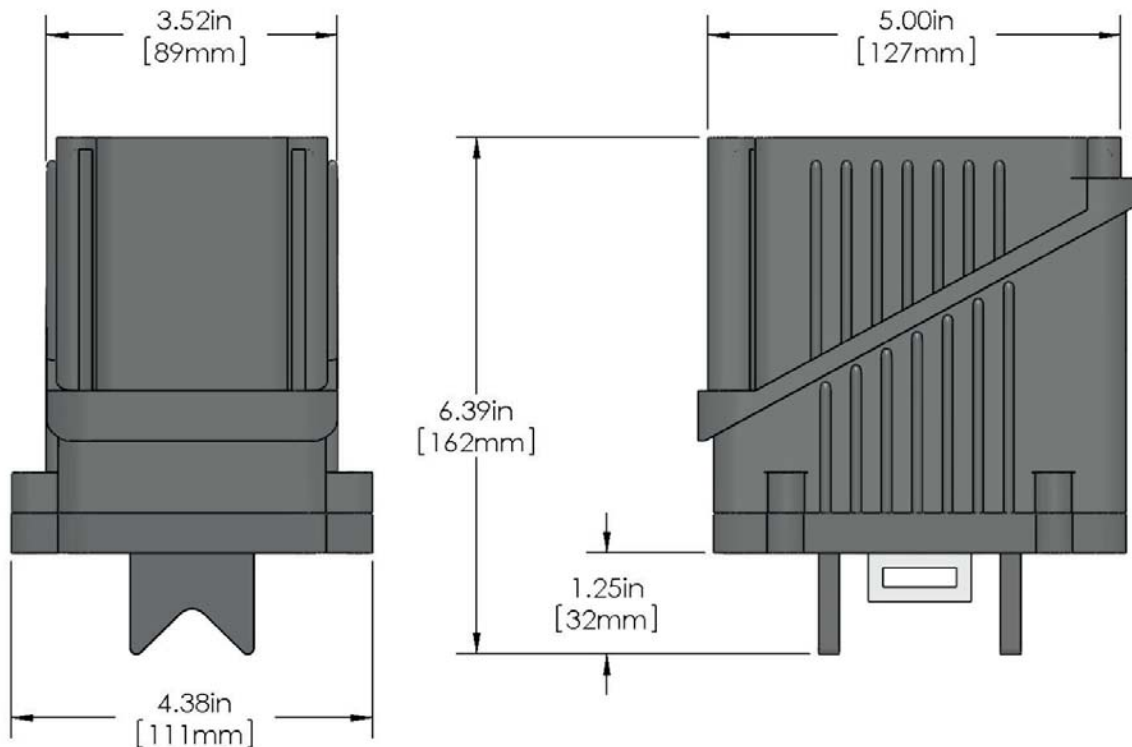

⚠ WARNING

HAZARD OF ELECTRIC SHOCK. Disconnect all power before starting. All installations must be effectively grounded in accordance with the National Electrical Code to eliminate shock hazard.

⚠ WARNING

Turn off power before removing junction box cover at all times.

⚠ WARNING

Users should install adequate controls and safety devices with their electric heating equipment. Where the consequences of failure may be severe, back-up controls are essential. Although the safety of the installation is responsibility of the user, Chromalox will be glad to assist in making equipment recommendations.

Cable Installation Instructions: CPM, SRL, CPR, SRM/E, SRP CZH, CWM cable special instructions denoted by *

1. Punch out the knockouts on the bottom of the box which correspond to the openings in the base through which the heating cable passes. Only punch out the knockouts that are to be used. If one is mistakenly punched, blank grommets can be ordered to re-establish the water tight seal.

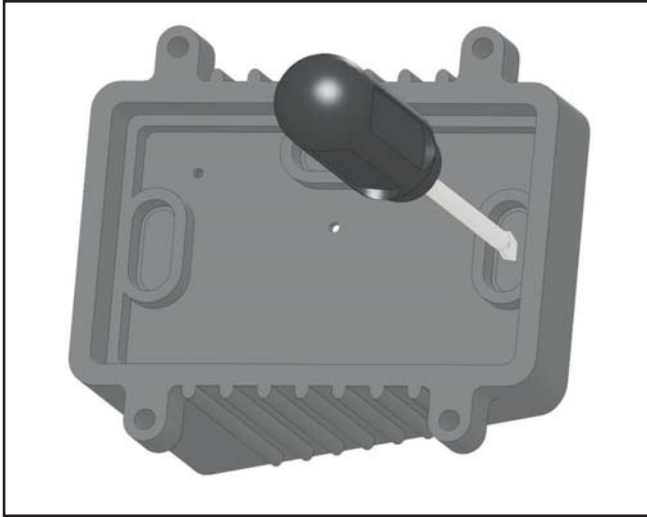

2. Feed the ends of the cables through the appropriate hole in the base. Allow 8 inches of cable to extend above the top of the base.

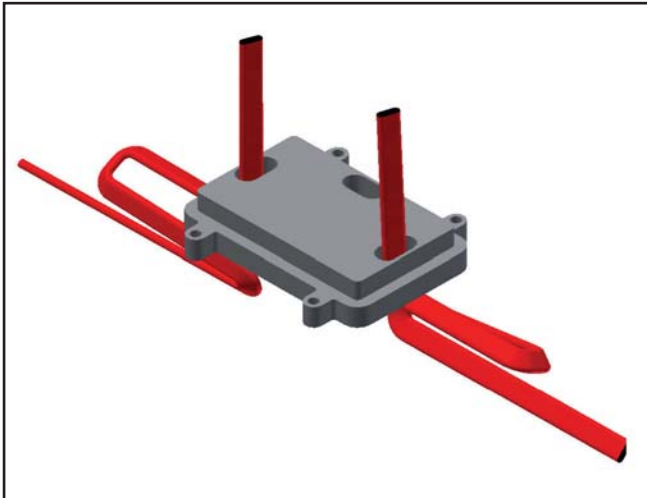

3. Slide cable grommets over the end of the cables and insert it into the opening in the base. Secure the base to the pipe by threading the appropriate sized pipe strap through the slot in the mounting plate. Tighten the pipe strap until the base is securely attached to the pipe.



4. Score the outer insulation 7 inches from the end of the cables. Remove the jacket to expose the metal braid. CAUTION: When removing outer jacket, be careful not to damage the braid of the base cable insulation. NOTE: If using braid only cable (-C) skip this step.

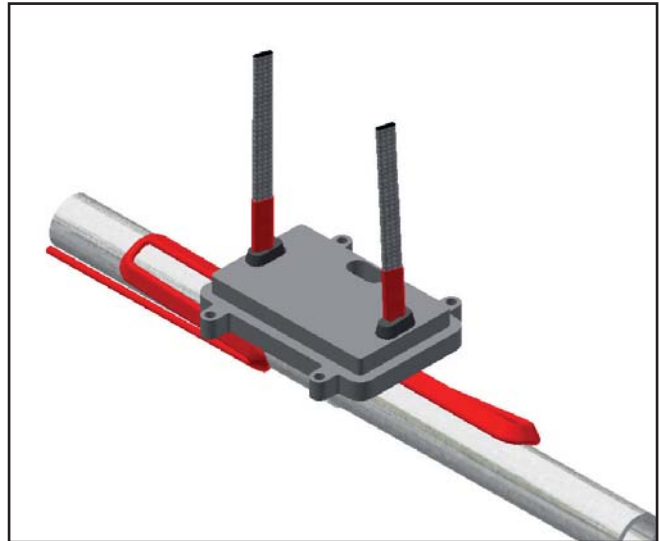

5. Feed cables through the corresponding holes in the box and secure box to base using all four screws (item 5).

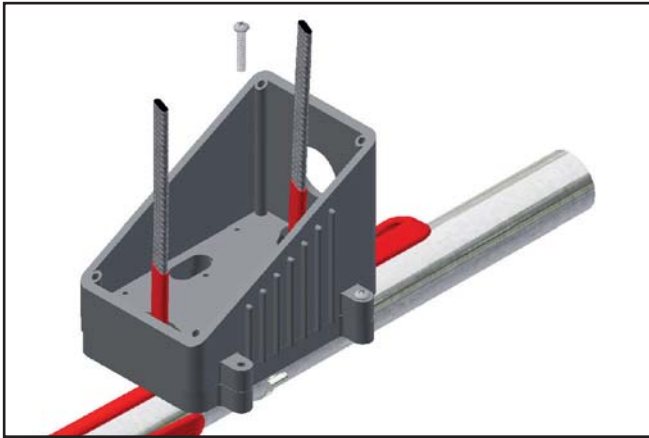

6. Starting from the end of the cables, unravel 2-1/2 inches of the braid. Twist the strands together to form a pigtail. ***For Tee splices only: Align and tape together two (2) cables 1-1/2 inches from the end. Twist the corresponding conductors (and braid pigtails if present) together.

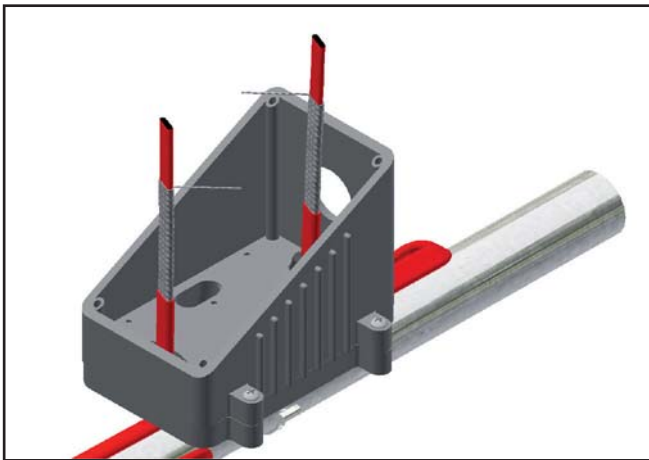

7. Using standard electrical cutters, cut a 3/4 in long notch out of the cable between the conductor wires. Bare a 3/8 inch length of each conductor by stripping off the outside insulation and the inner black core material.

***If using CZH, CWM score the outer jacket 3/4 inch from the end of the cable and remove the jacket. Cut off the exposed nichrome wire, pushing any remainder back under the jacket. Separate the buss wires and strip off the last 3/8 of the insulation from around both buss wires.

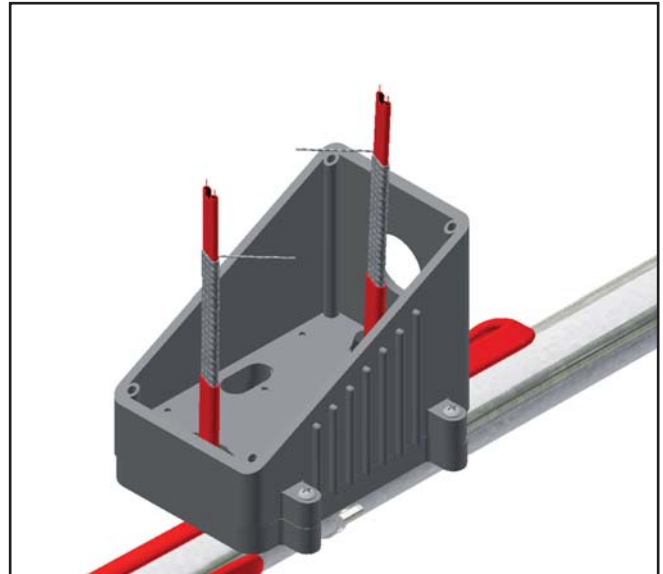

8. Insert the bared ends of the conductors and the braid into the openings in the terminal block. Tighten screws firmly to hold the wires and braid in place.

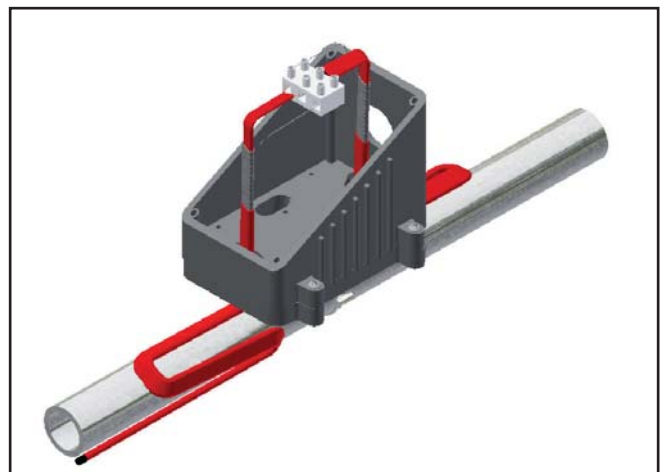

9. Mount terminal block to bottom of the box by driving the self-tapping screw (Item 8) provided into the mounting hole as shown.

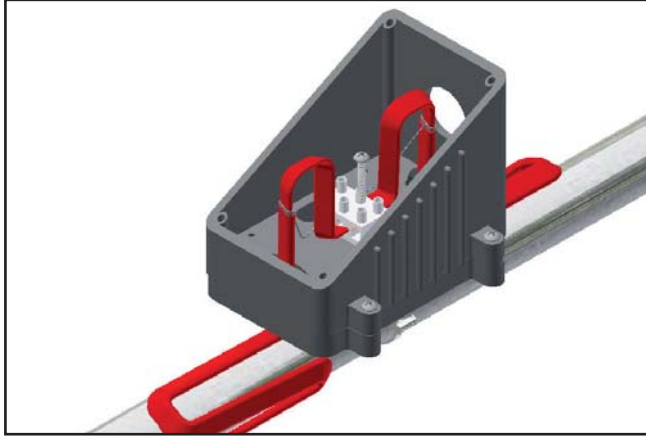

10. Carefully push the all wires into the box and secure the lid to the box. Make sure water tight rubber gasket (Item 5) is in place.

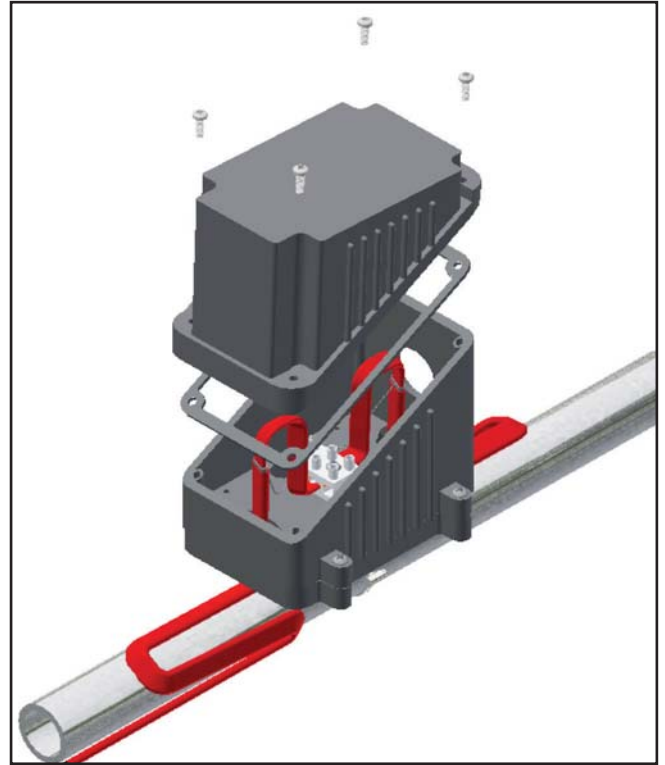

Limited Warranty:

Please refer to the Chromalox limited warranty applicable to this product at http://www.chromalox.com/customer-service/policies/terms_of_sale.aspx.