

TRACON[®] MODEL GPT-230

DUAL-POINT HEAT-TRACE CONTROL THERMOSTAT



TABLE OF CONTENTS

GPT 230 Overview.....	2
Installation	3
Power Source and Load Connections.....	4
Temperature Sensor Installation.....	5
Panel Lockout and External Alarm	6
Operation	6
Controls and Screens.....	9
Settings Screen Viewing/Editing Setting.....	10
Specifications	11

Pilot Duty

Pilot Duty

The GPT 230 General Purpose Thermostat with GFEP cannot be used for Pilot Duty applications.

Devoir du pilote

Le thermostat à usage général GPT 230 avec GFEP ne peut pas être utilisé pour les applications Pilot Duty.

Resistive Load Usage Only

This product is not for use with Inductive loads. Inductive loads may create nuisance tripping of the Ground-Fault Equipment Protection circuit.

Utilisation de charge résistive uniquement

Ce produit n'est pas destiné à être utilisé avec des charges inductives. Les charges inductives peuvent créer un déclenchement intempestif du circuit de protection de l'équipement contre les défauts à la terre.

Abnormal Odor or Smoke

In the event of smoke or a burning or abnormal odor, immediately interrupt power to the unit by turning off the circuit breaker protecting the unit.

Odeur ou fumée anormale

En cas de fumée ou de brûlure ou d'odeur anormale, coupez immédiatement l'alimentation de l'unité en fermant le disjoncteur protégeant l'unité.

Electrical Shock / Fire Hazard

Any installation involving electric heater wiring must be grounded to earth to protect against shock and fire hazard. Suitable ground fault detection and interrupting systems must always be in use to reduce shock and fire hazard and to protect equipment.

Electric wiring to heating elements must be installed in accordance with National Electrical Code (NEC)/ Canadian Electrical Code requirements, as well as all other local and applicable electrical codes and any third-party standards. This product is intended for commercial and industrial applications. Follow the installation instructions contained in this manual and those provided by the heater manufacturer.

Size the circuit breaker appropriately for the expected load and inrush current. The maximum rated current for the GPT 230 is 30 amps with resistive load.

Heater loads and their controls should not share a circuit branch with other types of equipment. A shared circuit may result in electromagnetic interference that can affect system operation. Make certain that the heater shield is properly grounded. Failure to do so may result in damage to the equipment or fire.

Following installation and prior to beginning system operation, refer to and perform the Post-Installation Test described in this manual.

Risque de choc électrique / d'incendie

Toute installation impliquant un câblage de chauffage électrique doit être mise à la terre pour se protéger contre les chocs et les risques d'incendie. Des systèmes appropriés de détection et d'interruption des défauts à la terre doivent toujours être utilisés pour réduire les risques de choc et d'incendie et protéger l'équipement.

Le câblage électrique des éléments chauffants doit être installé conformément aux exigences du Code national de l'électricité (NEC) / du Code canadien de l'électricité, ainsi qu'à tous les autres codes électriques locaux et applicables et à toute norme tierce. Ce produit est destiné à applications commerciales et industrielles. Suivez les instructions d'installation contenues dans ce manuel et celles fournies par le fabricant de l'appareil de chauffage. Dimensionnez le disjoncteur en fonction de la charge et du courant d'appel attendus. Le courant nominal maximum pour le GPT 230 est de 30 ampères avec une charge résistive.

Les charges de chauffage et leurs commandes ne doivent pas partager une branche de circuit avec d'autres types d'équipement. Un circuit partagé peut entraîner des interférences électromagnétiques qui peuvent affecter opération Système. Assurez-vous que le blindage du radiateur est correctement mis à la terre. Ne pas le faire peut endommager l'équipement ou provoquer un incendie.

Après l'installation et avant de commencer le fonctionnement du système, reportez-vous et effectuez le test de post-installation décrit dans ce manuel.

ITEMS INCLUDED

QTY.	P/N	DESCRIPTION
1	25171	TRACON MODEL GPT 230 Dual-Point General Purpose Heat-Trace Control
2	25076	Temperature Sensor
1	25300	GPT 230 Installation Sheet

OVERVIEW

The TRACON GPT 230 Dual Channel Heat-Trace Control is a dual-point microprocessor-based heat-trace control thermostat. It is ideal for applications which require two independent heater-control Channels with Ground-Fault Equipment Protection (GFEP). Ideal uses include freeze protection, hot water temperature maintenance, grease line trace, tank heating, and other temperature monitoring and control applications. The GPT 230 and its heater load can be powered with an available line voltage source of 100 - 277 V ac. The controller and heater load are powered from the same supply connection. The two internal load contactors are rated to switch up to 30 A resistive. The adjustable GFEP function provides additional safety and compliance with national and local electrical codes. The unit's housing is a NEMA 4X IP66 weather-resistant enclosure for enhanced durability.

FEATURES AND BENEFITS

- Dual channel heat trace capabilities allows for complete control and monitoring of two separate channels from one unit
- Adjustable temperature setpoint allows precise control of a wide range of processes
- Can use NEC Class 2 temperature sensors with up to 2,000 ft. cable for enhanced installation options
- Two thermistor temperature sensors with 20 ft. cables included for applications of -40 °F to 230 °F (-40 °C to 110 °C)
- RTD input allows higher accuracy and extreme-

temperature applications

- The unit can accommodate RTD sensors with 3-wire configuration
- Temperature display for accurate adjusting and monitoring
- Load current display for accurate adjusting and monitoring
- Ground fault current display for accurate monitoring, protection, and alarm
- Adjustable alarm thresholds for excess ground fault current, load current, and temperature
- Alarms indicated with panel display and relay contact for remote signaling
- A Fault Mode setting which can be set to energize or de-energize the heaters during a sensor failure
- Fire Protection Mode maintains heater operation for use in critical fire protection systems
- Durable weather-resistant NEMA 4X IP66 enclosure permits indoor or outdoor installation

The GPT 230 is permanently connected equipment and does not have an internal disconnect device. The installer must provide an accessible disconnect device, with short circuit and overcurrent protection (these are not supplied by Environmental Technology Inc). When power is applied, the system will start.

INSTALLATION

The GPT 230 Dual Channel Automatic Heat-Trace Control should be installed by a qualified, licensed electrician. Installation must conform to all applicable local and national electrical codes and laws. The unit's NEMA 4X IP66 enclosure allows for indoor or outdoor applications.

The GPT 230 controller has an ambient operating temperature range of -40°F to 122°F (-40°C to 50°C). To avoid potential internal condensation mount the unit out of direct sunlight.

Install the GPT on a fixed, flat, vertical surface using the unit's mounting flanges. The mounting flanges accommodate $1/4"$ or 6.3 mm fasteners.

Use only Listed Type 4X IP66 liquid-tight conduit hubs or cable glands. Connect the hub to the conduit system before connecting the hub to the enclosure.

The GPT 230's nonmetallic enclosure has two 1.046" holes for conduit entry; this can hold both power and load wiring. The installer can cut a second hole in the bottom or right, for separate line and load conduits.

The unit comes with two installed liquid-tight cable glands. These fittings are for temperature sensor and alarm relay cables.

The cable glands can accommodate cable diameters 0.08" to 0.24" (2 mm to 6 mm). The temperature sensors may be located up to 2,000' (610m) from the GPT.

There is a removable electrical insulation divider that must be in place when there is power applied to the unit.

All leads should be terminated; no unsecured leads should be left inside the wiring compartment.

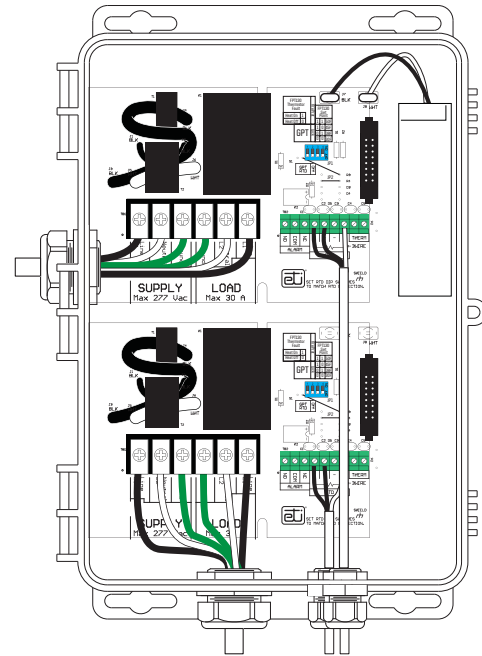

FIGURE 1. The GPT 130 wiring layout

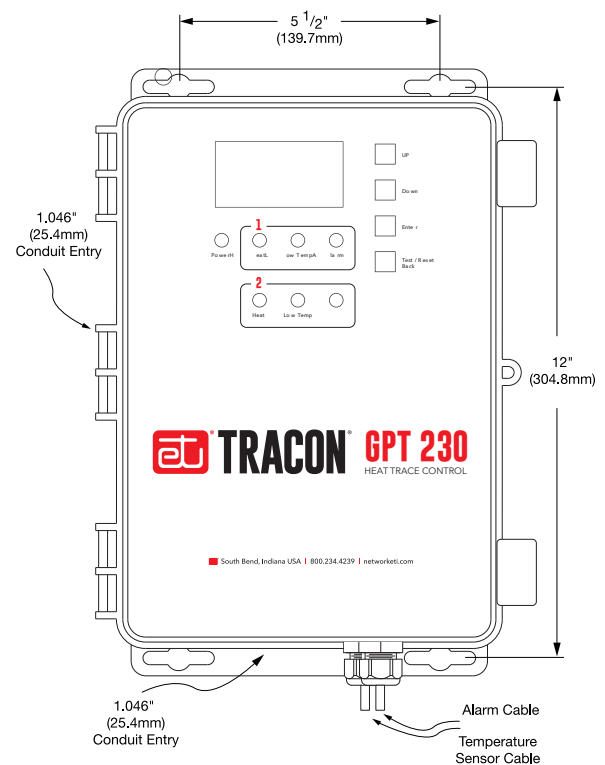

FIGURE 2. Mounting Dimensions

POWER SOURCE AND CONTACTOR CONNECTIONS

Supply Voltage

The GPT 230 operates from 100 - 277 V ac at 50/60 Hz. This control and its heater load should not share a circuit branch and circuit breaker with other types of equipment. A shared circuit may result in electromagnetic interference that can affect system operation. For line supply and load connections, use 10 AWG wires rated for at least 194 °F (90 °C). The connections are shown in Figure 3 and Figure 4.

FIGURE 3.1
Contractor
Connections

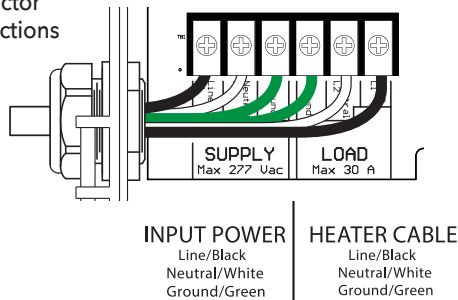
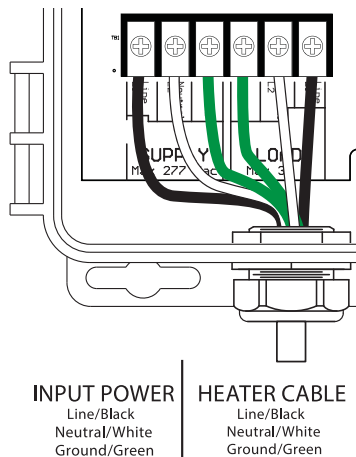

FIGURE 3.2
Contractor
Connections



Contactor Ratings

The heater contactor provides two (2) Form A (DPST) contacts rated for heater loads up to 30 A ac and 277 V ac. These two contacts are used to control both legs of the input power (Line and Neutral).

Manual Load Test

To manually energize the load, select the Settings screen and then hold Test/Reset pushbutton for five seconds. The output will switch on and stay on for five minutes or until Test/Reset key is pressed again. A manual load test is recommended upon installation to verify heater function and load current.

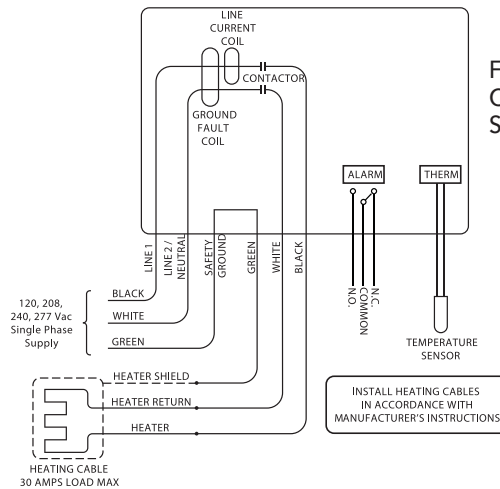

FIGURE 4.1
Connection
Schematic

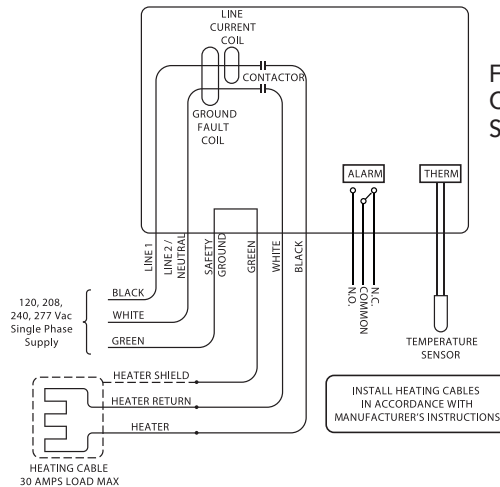

FIGURE 4.2
Connection
Schematic

TEMPERATURE SENSOR

Each channel of the GPT 230 can use either a thermistor (provided), or a 3-wire RTD sensor. When using Sensor Sharing (see page 11), one sensor, connected at channel 1, is used to control both channels.

Thermistor (25076)

The GPT 230 comes with two Thermistor temperature sensors with 20 ft. jacketed cables that have an operating range of -40°F to 230°F (-40°C to 110°C). See Figure 5 for proper wiring when using thermistor sensors.

RTD

The unit can use RTD sensors for applications requiring a wider temperature range. The GPT 230 can operate with 3-wire RTD sensors. See Figure 5 for proper wiring when using a 3-wire RTD sensor.

Note: The sensor must be selected in the Sensor Type parameter setting screen.

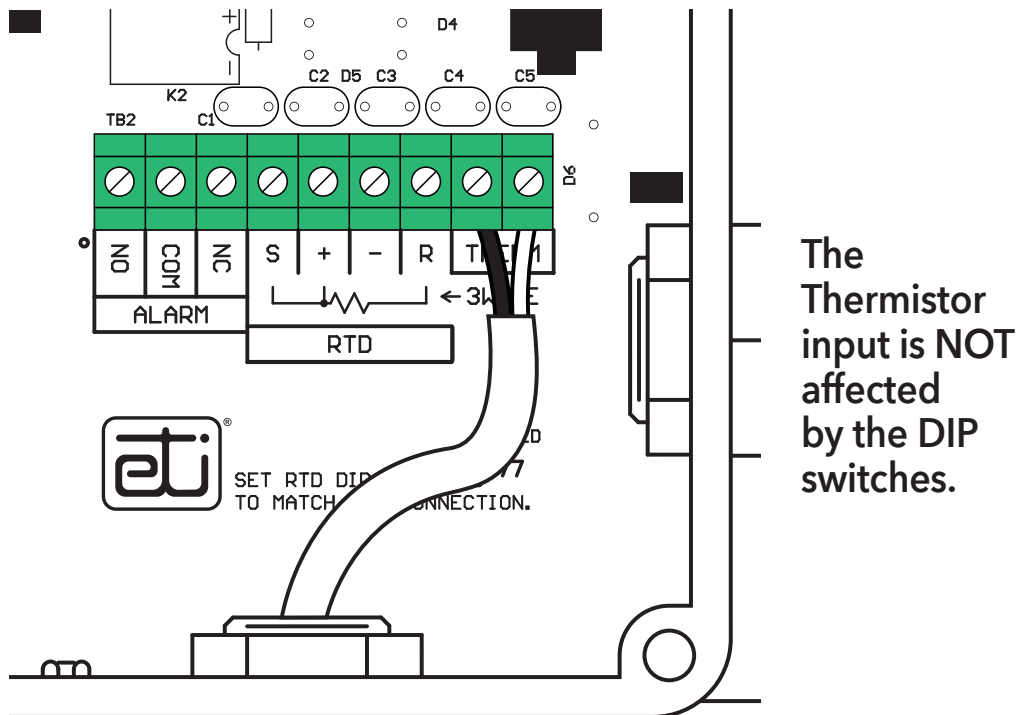
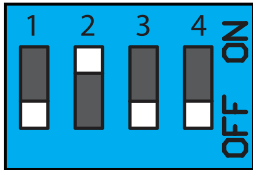

FIGURE 5. Temperature sensor wiring



Setting for Panel Lockout ON (default is OFF)

FIGURE 6. Panel lockout DIP switch configuration

PANEL LOCKOUT

To prevent unauthorized changes of control settings, the second DIP switch can be set to the on position to Lock the settings. With Lock enabled, the control panel will allow viewing but not changing any of the settings; only the °C or °F option can be changed. See Figure 6.

Note: The GPT reads the Lock DIP switch position when the Settings screen is entered. If the switch is changed, you need to re-enter the Settings screen.

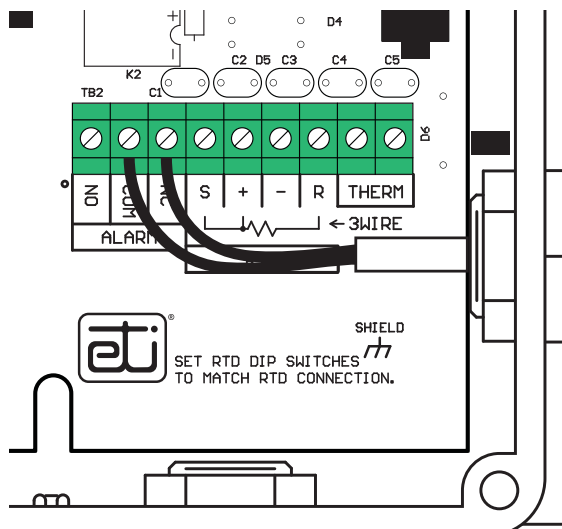

Wiring to Normally Closed Alarm Contact

FIGURE 7. External alarm connection

EXTERNAL ALARM

Alarm Connections

An alarm or power-off condition can be communicated by either opening or closing a relay contact. It is important to make the proper alarm relay connections to achieve the desired result. The middle terminal labeled COM (Common) is used in both wiring configurations. Connect one alarm relay lead to the COM terminal.

If the system needs a contact to close to signal an alarm or power-off condition, connect the other alarm relay lead to the NC (Normally Closed) terminal. See Figure 7.

If the system needs a contact to open to signal an alarm or power-off condition, then connect the other alarm relay lead to the NO (Normally Open) terminal.

If the unit has power, and there are no alarm conditions then the NO and COM terminals will be connected. If the unit loses power or an alarm condition occurs then the NC and COM terminals will be connected.

Note: The "Normally" condition of the relay is the alarm condition for the unit.

OPERATION

The GPT 230 can maintain temperatures from a setpoint ranging from -99.9°F to 999.9°F (-73.3°C to 537.7°C). The usable temperature range is sensor dependent. The heater will energize when the temperature drops below the designated setpoint. The heater will de-energize when the temperature meets the designated High Temperature.

The GPT 230 features ETI's patented self-testing GFEP, which switches the system off when it detects excessive ground current leakage. The GFEP eliminates the extra expenses associated with having to provide an external GFEP.

Alarms

Critical Alarms are Latching alarms and include Ground Fault, High Current, Stuck Relay, Internal Circuit, and

Power Fail. Critical alarms always turn off the heat, unless Fire Protect Mode is ON. To continue normal operation, any of these will require a manual reset. The manual reset (TEST/RESET BACK pushbutton) will start a self test, and if all Critical Alarms are cleared then normal operation will resume.

Non-critical Alarms can be Latching or Non-Latching depending on the Latching setting alarms and include Low Current, Low Temperature, High Temperature, and Sensor Fault. A Sensor Fault will stop temperature regulation (with heat on or off depending on the Fail Mode setting), but as soon as the sensor is corrected, then operation will immediately resume. The other Non-critical Alarms do not inhibit operation.

Note: Latching alarms require manual clearing to resume operation.

The Manual Self Test clears all alarms, checks Ground Fault Current, and checks Low Current if the Low Current delay is set to five seconds or less. The Auto Self Test does not clear alarms, but otherwise functions the same as the Manual Self Test.

GPT 230 Front Panel

Indicator Lights (See Figure 8.)

- POWER indicator - This green LED indicates that the GPT 230 is receiving power.
- HEAT indicator - This yellow LED indicates when the heater is energized.
- LOW TEMP indicator - This blue LED indicates when sensors detect temperature has fallen below the Low Temp Alarm threshold.
- ALARM indicator - This red LED indicates when there is high ground fault current detected or any other alarm condition exists.

Note: Because the unit has no ON/OFF power switch, power runs to the unit as soon as facility power is connected to it. When the unit has power, the green POWER indicator will be lit.



FIGURE 8. GPT 230 front panel

GPT 230 CONTROLS AND SCREENS

CONTROLS

Pushbuttons

- UP and DOWN pushbuttons - These black pushbuttons change the display and menu screens. They are also used for changing settings or values within the menus.
- ENTER pushbutton - This green pushbutton is for selecting and entering settings or values within the menu.
- TEST/RESET BACK pushbutton - This red pushbutton has the following functions:
 - To test the ground fault detector circuit itself AND to test for a ground fault when the heat load is not energized (the heater will energize during the test). This will also test for Low Current if the Low Current delay setting is set to 5 seconds or less. Note: whenever the heat is on, the unit is continuously checking for a ground fault.
 - To reset the system after a ground fault. If the ground fault no longer exists, then normal operation will resume.
 - Clearing any other latched alarm conditions if the alarm condition no longer exists.

- On settings menus this pushbutton backs out of an operation without changing anything.
- Energizes heater for system testing or troubleshooting. Pressing this pushbutton for five seconds while on the Edit Settings screen will energize the heater for five minutes. Pressing the pushbutton again will de-energize the heater and resume normal operation.

MAIN SCREENS

There are five main screens that can be accessed using the UP and DOWN pushbuttons. These screens cycle in the sequence shown in Figure 9; pressing UP or DOWN five times returns you to your starting position.

Note: After initial use the default display screen when left alone will be the last main screen that was displayed for more than five seconds.

Triple Display screen - Displays the three data fields (Temperature, Load Current, Ground Fault Current) are all shown on this same screen. If there is an alarm, the field description will alternate with an alarm notification. In most cases, the alarm on this screen will identify what the alarm is, except for a Load Current alarm. To determine whether the Load Current alarm is a high or low Load Current alarm you must view the Load Current Display screen.

Note: If the heater relay is off, the ground fault number is NOT shown.

Temperature Display screen - Indicates the current temperature in Fahrenheit or Celsius. This screen will also show any alarm conditions.

Load Current Display screen - Indicates the load current to the heaters in amps. This screen will also show any alarm conditions.

Ground-Fault Current Display screen - Indicates the ground fault current in milliamps. This screen will also show any associated alarm conditions.

Note: If the heater relay is off, the ground fault number is NOT shown.

Note: In any of the main sequence screens, pressing the TEST/RESET BACK pushbutton will clear all latched alarms and perform a self-test, including a ground fault current test. The "Passed" or "Failed" result of the self-test is then displayed, then returns to the default screen.

Settings screen - Allows access to all the parameter settings. The top line will say "Edit Settings" or "View Settings", depending on whether the Panel Lockout function is set with the internal DIP switch (see page 7). With Panel Lockout enabled, most configuration settings can only be viewed, not edited. The only exception is the choice of Celsius or Fahrenheit temperature units.

Note: The GPT reads the Lock DIP switch position when the Settings screen is entered. If the switch is changed, you need to re-enter the Settings screen.

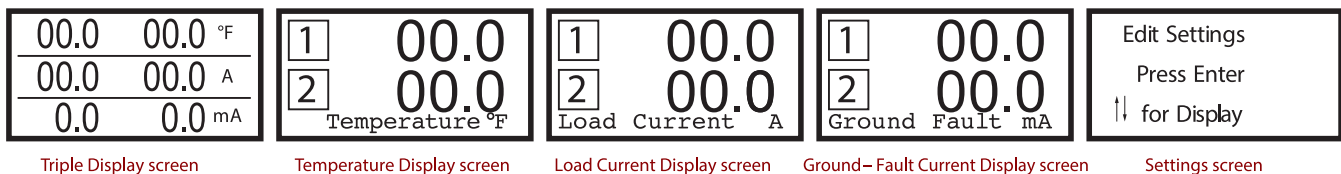

FIGURE 9. Main screen sequence

GPT 230 SETTINGS SCREEN VIEWING/EDITING SETTINGS

SETTINGS SCREENS

To enter the Settings sequence press the ENTER pushbutton while in the Settings screen. This will take you to the Settings sequence, where you can view or edit system parameter settings. These screens follow the sequence shown in Figure 10; pressing the UP or DOWN pushbuttons 21 times returns you to your starting position.

Note: The Settings screens cycle a circular sequence. The first time the Settings sequence is accessed the sequence will start with the Sensor Sharing screen, every time after that when accessed the Settings sequence will start with the Control Temps 1 screen.

Each screen has a line at the top which describes the parameter or group of parameters. Press the ENTER pushbutton to edit the parameter or group of parameters. If the Panel Lockout feature is turned on you will see a screen that says "Edit Function Locked Out". The BACK pushbutton will take you back to the default screen.

All settings are stored in the unit's non-volatile memory, this means that the GPT 230 will retain the inputted settings even if the unit loses or is disconnected from the power source. Holding the UP and DOWN pushbuttons together for five seconds in the settings screen will restore all settings to their factory default value.

Basic Editing of Settings

When on the desired screen press the ENTER pushbutton to edit the values. Use the UP and DOWN pushbuttonsto change the parameter values, press the buttons quickly to change the number values decimally, or hold the buttons to scroll through the number values more quickly. The ENTER pushbutton saves the value setting. The BACK pushbutton cancels the edit operation if not saved and returns to the original value at the start of the edit.

Multi-field Screen Editing

In screens that display multiple fields, there are two columns. The left column displays the name of the parameter, and the right column displays the current value. Initially, one of the fields in the left column will be selected (have a selection box around it). Use the UP and DOWN pushbuttons to change the row which is selected. Press the ENTER pushbutton to edit the parameter in that row, the selection box will move to the right column, indicating that an edit operation is in process. After you are done editing, press the ENTER pushbutton to save the new value, or the BACK pushbutton to make no change. The selection box will move back to the left column.

Alarm Options Screen Editing

The "Alarm Options" screen has three binary (on/off) configuration settings:

Latching: this controls whether non-critical alarms latch. When ON, alarms need to be cleared manually by using the red key. When OFF, the alarm will go away when the alarm condition resolved. The default for the Latching setting is OFF.

Fail Mode: this is a safe state setting which can be set to energize or de-energize the heaters if the sensor fails. The default setting for the Fail Mode is ON.

Fire Prot: this controls whether the Fire Protection mode is active. When ON, a ground fault or over-current alarm will not inhibit operation of the heater. When OFF, a ground fault or over-current alarm will de-energize the heater. The default setting for the Fire Protection mode is OFF. When in the edit mode the description and meaning of the currently selected parameter is displayed at the bottom. As you edit the value, the description will change accordingly.

Note: To restore all settings to factory default press both the UP and DOWN pushbuttons together for five seconds, while in the settings screen. The unit will prompt you for acknowledgment before changing the setting.

SETTING SCREENS

Note: Screens with a number "1" in the upper right corner indicate that these settings are for Channel 1. There is a second set of these screens for Channel 2 which have a "2" in the upper right hand corner. The Channel 2 Settings screens will follow the Channel 1 Settings screens in the Settings sequence.

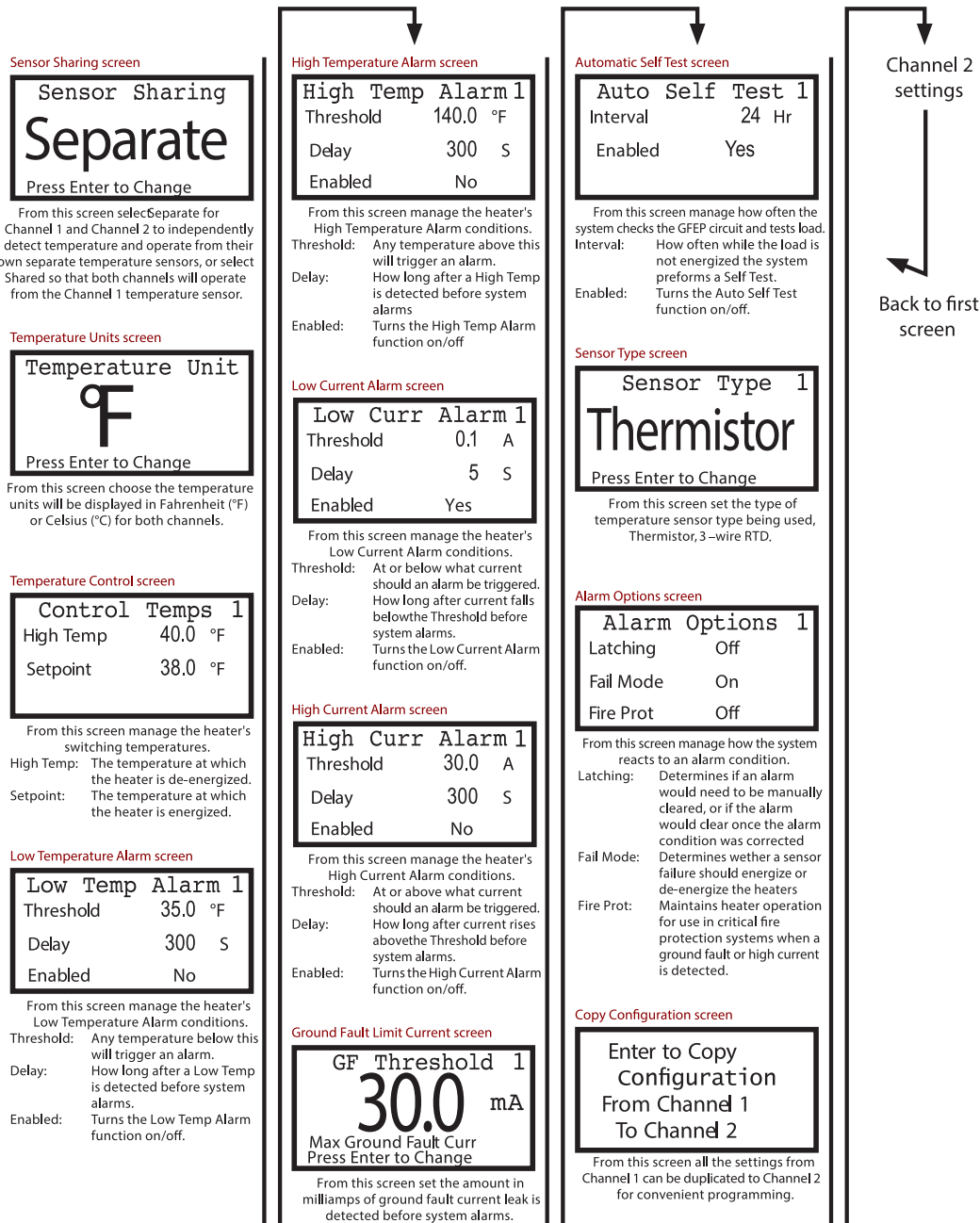

FIGURE 10. Setting screen sequence

SPECIFICATIONS

General

Certifications	UL 60730-1, UL 1053, CSA E60730-1:13
----------------	---

Environmental

Area of use	Nonhazardous locations
Operating temperature range	-40 °F to 122 °F (-40 °C to 50 °C)

Enclosure

Dimensions	9.0" (W) x 12 4/5" (H) x 5 9/10" (D) 2229 mm (W) x 325 mm (H) x 150 mm (D)
Ingress protection	NEMA 4X, IP66
Cover attachment	Polycarbonate cover, plastic screws
Cable entries	Two liquid-tight cable glands installed for sensor and alarm leads, cable diameter 0.08" to 0.24" (2 mm to 6 mm) One 1.046" hole to accommodate a 3/4" conduit fitting for power wiring connection

Material	Polycarbonate
----------	---------------

Weight	5.8 lb. (2.63 kg)
--------	-------------------

Mounting	Wall mount with flanges
----------	-------------------------

Wiring Terminal Ratings

Power	Barrier Strip Terminals for Line, Neutral, and Ground; use 10 AWG wires rated for at least 194 °F (90 °C)
-------	---

Sensors	Terminal Block, rising cage clamp, 12-28 AWG leads
---------	--

Alarm	relay Terminal Block, rising cage clamp, 12-28 AWG leads
-------	--

Parameter Settings

Temperature setpoint heat ON	Adjustable -99.9 °F to 999 °F (-73.3 °C to 537.7 °C) Default 38 °F (3.33 °C)
------------------------------	--

Temperature setpoint heat OFF	Adjustable -99.9 °F to 999 °F (-73.3 °C to 537.7 °C) Default 40 °F (4.44 °C)
-------------------------------	--

Low-temperature alarm threshold	-99.9 °F to 999 °F (-73.3 °C to 537.7 °C) Default 35 °F (-1.7 °C) Disabled
---------------------------------	--

Low-temperature alarm delay	0 s to 3000 s Default 300 s
-----------------------------	-----------------------------

High-temperature alarm threshold	-99.9 °F to 999 °F (-73.3 °C to 537.7 °C) Default 140 °F (60 °C) Disabled
----------------------------------	---

High-temperature alarm delay	0 s to 3000 s Default 300 s
------------------------------	-----------------------------

Low-current alarm threshold	0.0 A to 10.0 A Default 0.1 A Enabled
-----------------------------	---------------------------------------

Low-current alarm delay	0 s to 300 s Default 5 s Enabled
-------------------------	----------------------------------

High-current alarm threshold	0.0 A to 55.0 A Default 30.0 A Disabled
------------------------------	---

High-current alarm delay	0 s to 600 s Default 300 s
--------------------------	----------------------------

Ground fault limit current	1.0 mA to 300.0 mA Default 30 mA
----------------------------	----------------------------------

Self-Test Interval	1 h to 250 h Default 24 h Enabled
--------------------	-----------------------------------

Temperature Unit	°F or °C Default °F
------------------	---------------------

User Interfaces

Pushbuttons	UP, DOWN, ENTER, TEST / RESET BACK
-------------	------------------------------------

DIP switches	Panel lockout
--------------	---------------

Remote Interface

Alarm relay	Isolated SPDT 1 AMP Class 2 contact per channel
-------------	---

Indicators

Status indicator	Power (Green) Heater (Yellow) Low Temperature (Blue) Summary alarm (Red)
------------------	---

Display	2.7" OLED graphic 128x64
---------	--------------------------

Summary alarm relay reporting	Low temperature High temperature Low load current High load current High ground fault current Stuck relay Sensor fault Internal fault
-------------------------------	--

Control Ratings

Temperature accuracy	+/- 2 °F (1 °C)
----------------------	-----------------

Temperature Sensors

Temperature inputs	(Included) Thermistor: 100k ohms at 25 °C, range -40 °F to 230 °F (-40 °C to 110 °C), 20ft Lead (25076) RTD Sensor (SOLD SEPERATELY) : Platinum, Alpha = 0.00385, ITS-90, 100 ohms at 0 °C, Input supports 3-wire connection, Sensor operates at 1 mA
--------------------	---

GFEP (Ground-Fault Equipment Protection)

Operation	Continuously tests ground fault current whenever the load is on; also manually and periodically tests equipment ground fault current with each self-test.
-----------	---

Range	Adjustable 1 mA to 300 mA, Default 30 mA
-------	--

Automatic self-test	Verifies GFEP functionality every 24 hr. and whenever the load is energized
---------------------	---

Power

Supply voltage	100 - 277 V ac 50/60 Hz
----------------	-------------------------

Controller power consumption	7 W maximum, 2.2 W idle
------------------------------	-------------------------

Load rating	30 A, 100 - 277 V ac resistive
-------------	--------------------------------

LIMITED WARRANTY

ETI's two year limited warranty covering defects in workmanship and materials applies. Contact Customer Service for complete warranty information.

DISCLAIMER

ETI makes no representations or warranties, either expressed or implied, with respect to the contents of this publication or the products that it describes, and specifically disclaims any implied warranties of merchantability or fitness for any particular purpose. ETI reserves the right to revise this publication, and to make changes and improvements to the products described in this publication, without the obligation of ETI to notify any person or organization of such revisions, changes or improvements.