

Installation & Operation Manual

ChromaMelt 3, ChromaMelt 3C & ChromaMelt 5



PK569
January 2021

Table of Contents

<u>Section</u>	<u>Page</u>
Introduction	5
ChromaMelt Installation Notes	6
Wiring	7
Wiring the ChromaMelt 5	7
Wiring the ChromaMelt 3C	8
Wiring the ChromaMelt 3	9
Wiring Options	10
Connecting Snow Sensors to the System	18
Operating Instructions	19
Turning the system ON and OFF	19
Selecting temperature scale	19
Selecting Automatic or Manual mode	19
Heaters indication	19
Snow flake icon and digital time indication	19
Technician Settings	20
Enter technician settings mode	20
P01 - Temperature set point	20
P02 - Lower limit temperature for heating	21
P03 - Upper limit temperature for heating	21
P04 - Time delay before stopping the heaters.....	21
P05 - Manual mode ON time	21
P06 - Heaters cycle and splitting time	22
P07 - Heater outputs logic by CS-AS or by 3rd party sensor	22
P08 - Snow sensor sensitivity	23
P88 - Snow detection threshold	23
P09 - Number of snow sensors connected	23
P10 - Test conditions mode	23
Save changes and return to normal display	23
Restore Default Values	24
Enable/Disable Zones	24
DIP Switch Settings	24
DIP switch S2 - Short measuring times (test only)	24
DIP switches S3 and S4 - heaters sequencing logic	25
Temperature Reading Errors	26
Ambient temperature sensor readings out of range	26
Communication error with one or more snow sensors.....	26
Upper limit temperature sensor is not connected or short circuit	26
Appendix 1 - Calibrating and Testing the Internal GFCI	27

Safety Precautions

IMPORTANT SAFEGUARDS



Safety precautions should always be followed to reduce the risk of fire, electrical shock, injury and even death to persons.

Please read all instructions before operating the Control Panel.



To avoid electrical shock or injury, always remove power before servicing a circuit. Personnel working with or near high voltages should be familiar with modern methods of resuscitation. Contact an area supervisor or safety personnel for more information.

⚠ WARNING



HIGH VOLTAGE is used in the operation of this equipment; DEATH ON CONTACT may result if personnel fail to observe safety precautions.

Learn the areas containing high-voltage connections when installing or operating this equipment.

Be careful not to contact high-voltage connections when installing or operating this equipment.

Before working inside the equipment, turn power off and ground all points of high potential before touching them.

⚠ WARNING



ELECTRIC SHOCK HAZARD. Any installation involving control equipment must be performed by a qualified person and must be effectively grounded in accordance with the National Electrical Code to eliminate shock hazard.

Before Powering Up

Chromalox takes great pride in knowing that we have provided to you a product of premium quality and workmanship. We have taken every precaution to ensure that your equipment arrives safe and secure.

However, vibration and temperature changes during shipping can cause some components to become loose. Additionally, throughout the life span of this product, other environmental and application conditions may have affected the mechanical and electrical continuity of several internal components. Therefore, for your safety and overall product performance, please take the time to familiarize yourself with the **MAINTENANCE, OPERATION, AND INSTALLATION INSTRUCTIONS** technical manual that was shipped with your panel.

Since it is not uncommon for electrical wiring and mechanical connections to become slightly loosened during shipment, we ask that you pay particular attention to the section titled Wiring and Connections:

WIRING AND CONNECTIONS



Check wiring and connections as follows:

- Inspect wiring for wear, fraying, chipping, nicks, and evidence of overheating. Repair minor defects with a good grade of electrical tape, or replace if needed.
- Inspect for loose electrical and mechanical connections. Tighten or replace defective crimp-style lugs. Re-solder loose solder connections. Tighten or replace all loose or missing hardware.

Introduction

The ChromaMelt 3/3C/5 power boxes together with the Controller and User Interface panel, offer smart and easy control over the ChromaMelt Snow & Ice Melting system.

It can operate up to 4 snow melting zones and one auxiliary zone, with selectable sequencing method.

Typical applications include driveways, sidewalks, loading docks, stairs, pavements and gutters.

The backlit LCD screen provides full interface and information of the system status.

The use of several zones staggering allow covering larger area for snow melting with a limited available electrical power.

The Controller and User Interface panel offers various operating and programming options such as:

- Switchable temperature scales (°F or °C)
- Both Automatic and Manual modes
- Adjustable heaters cycle and splitting times
- Adjustable heaters hold on, off & delay
- Optional auxiliary control by 3rd party snow sensor (e.g. Gutter sensor)
- Adjustable Lower ambient temperature limit to stop heaters (lockout)
- Energy saving upper temperature limit
- Adjustable snow sensor sensitivity (%Rh)
- Commissioning/Test mode

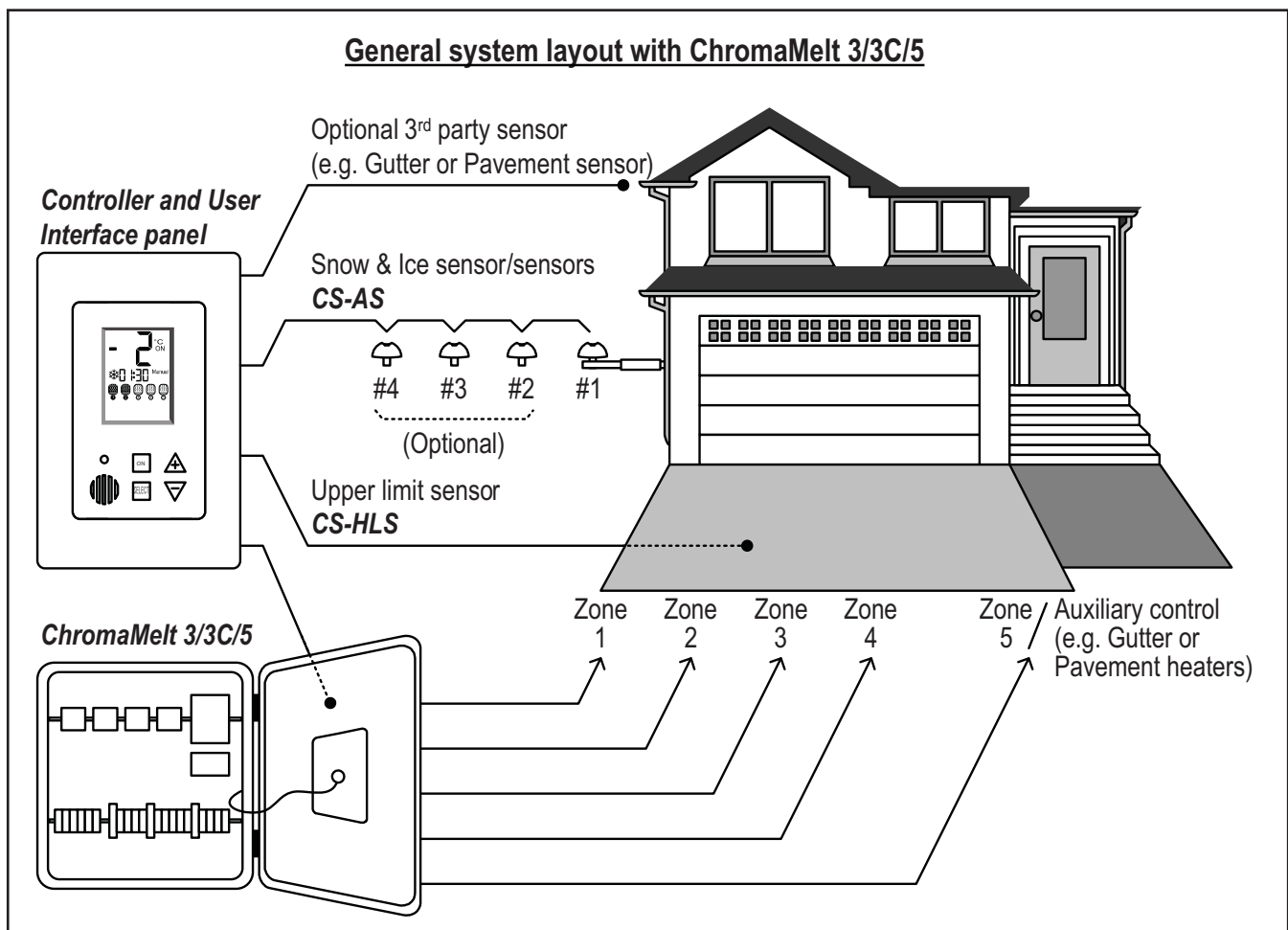

ChromaMelt Series Installation

PLEASE READ THIS MANUAL AND THE SAFETY WARNINGS CAREFULLY BEFORE INSTALLING AND USING THE CONTROLLER AND SAVE IT FOR FUTURE USE.

Installation notes

1. Familiarize yourself with the markings, warnings, components and terminology.
2. The ChromaMelt power boxes and its accessories must be installed by a qualified electrician in accordance with local regulations and the requirements of the NEC (NFPA 72) and the CEC part 1.

⚠ WARNING

Ensure the power is disconnect from all circuits before mounting the power box and making any connections. Contact with components carrying hazardous voltage can cause electric shock and may result in severe personal injury or death.

3. Installer must ensure the installation of approved disconnect means, for all power supply circuits feeding this unit.
4. The power boxes are suitable for indoor wall mount installation only.
5. Ensure wiring according to the provided schematics using copper conductors only.
6. Make sure the wire gauge (AWG) is suitable for the circuit amperage draw, as specified in the NEC/CEC table 1.
7. Ensure that the main breakers (fuses) are suitable for the heating systems rating (80% load).
8. Grounding means must comply with local regulations and CEC/NEC.

9. Ensure that the heating system/de-icing system connected to this unit complies with the UL 499 or UL 515 & CSA 22.2 # 130.3 standard and is certified / listed by an NRTL.
10. Ensure that all wiring is rated for the application at 60°C (140°F as per UL 515 CSA 22.2 #130 clause 12 table 12.1.
11. Ensure that any holes punched for conduit are to compromise the integrity of the enclosure ratings.

Ground fault circuit interrupter (GFCI)

1. The ground fault interrupter/residual current detector installed in this system is a Non class A GFCI, intended for equipment protection.
2. Familiar yourself with its operation and required setting.
3. At installation and commissioning stage use a calibrated milliamp meter to read and record the heating systems natural leakage.
4. Set the GFI/RCD to no more than 30 milliamps higher than that reading.
5. This step might have to be repeated a few times, to avoid nuisance tripping.
6. The GFCI should be tested monthly. Please refer to the calibration and testing instructions in appendix 1 of this manual.

Wiring the ChromaMelt 5

Heater Load Connection

1. Provide 3-Phase contactors C1, C2, C3 and C4 with up to 600 VAC, 50 AMP Maximum per pole.
2. Provide contactor C5 with with up to 277 VAC, 30 AMP.
3. Make sure the wire gauge (AWG) is suitable for the circuit Amperage draw, as specified in the NEC/CEC table 1.

Main supply for the power box

Provide terminals L1, N1 with 120 VAC supply.

Connection to 3rd party ice/snow sensor (GIT-1 / CIT-1 / SIT/6E) - option

- 3-wire shielded cable
- Up to 2,000 ft (609 m) using 12 AWG 3-wire shielded cable.
- Up to 500 ft (152 m) using 18 AWG 3-wire shielded cable.

Connection to snow sensor (CS-AS)

Please refer CS-AS installation section of this manual.

CAUTION

Incorrect voltage may cause fire or seriously damage the unit.

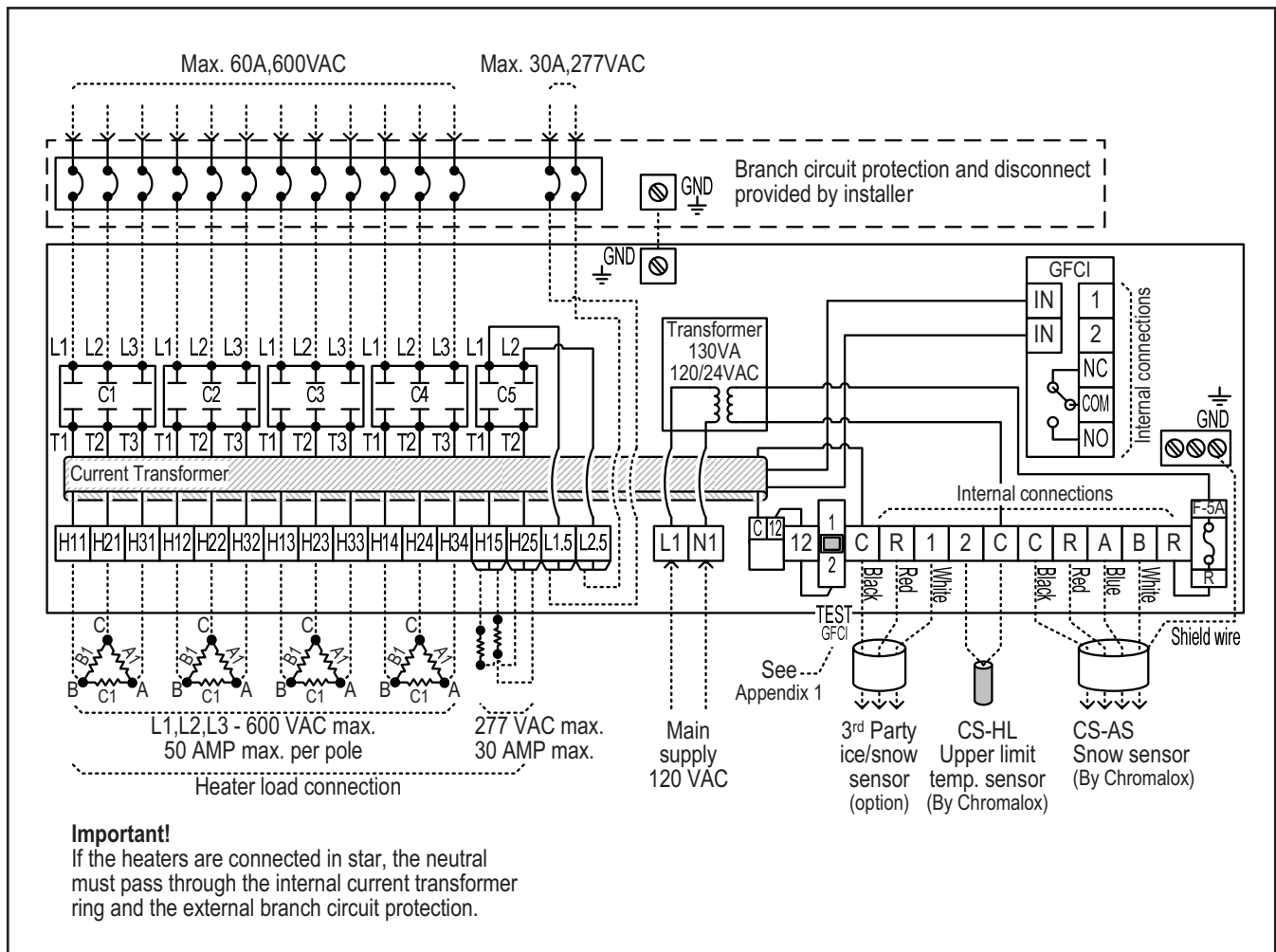

Wiring the ChromaMelt 3C

Heater Load Connection

1. Provide 3-Phase contactors C1 and C2 with up to 600 VAC, 50 AMP Maximum per pole.
2. Provide contactor C5 with with up to 277 VAC, 30 AMP.
3. Make sure the wire Gauge (AWG) is suitable for the circuit Amperage draw, as specified in the NEC/CEC table 1.

Main supply for the power box

Provide terminals L1, N1 with 120 VAC supply.

Connection to 3rd party ice/snow sensor (GIT-1 / CIT-1 / SIT/6E) - option

- 3-wire shielded cable
- Up to 2,000 ft (609 m) using 12 AWG 3-wire shielded cable.
- Up to 500 ft (152 m) using 18 AWG 3-wire shielded cable.

Connection to snow sensor (CS-AS)

Please refer CS-AS installation section of this manual.

CAUTION

Incorrect voltage may cause fire or seriously damage the unit.

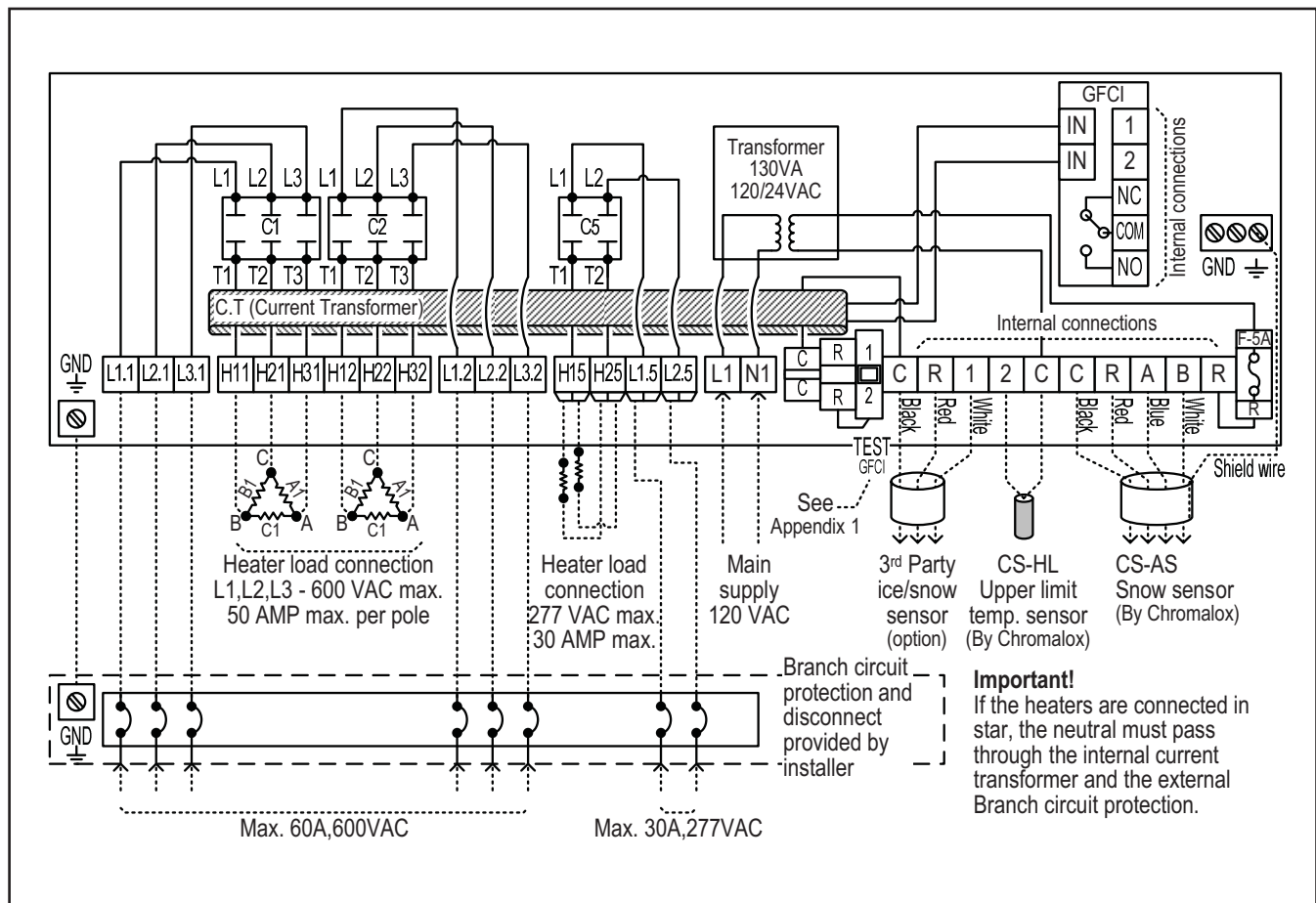

Wiring the ChromaMelt 3

Heater Load Connection

1. Provide contactors C1, C2, C3 and C4 with up to 277 VAC, 30 AMP.
2. Make sure the wire gauge (AWG) is suitable for the circuit Amperage draw, as specified in the NEC/CEC table 1.

Main supply for the power box

Provide terminals L1, N1 with 120 VAC supply.

CAUTION

Incorrect voltage may cause fire or seriously damage the unit.

Connection to snow sensor (CS-AS)

Please refer CS-AS installation section of this manual.

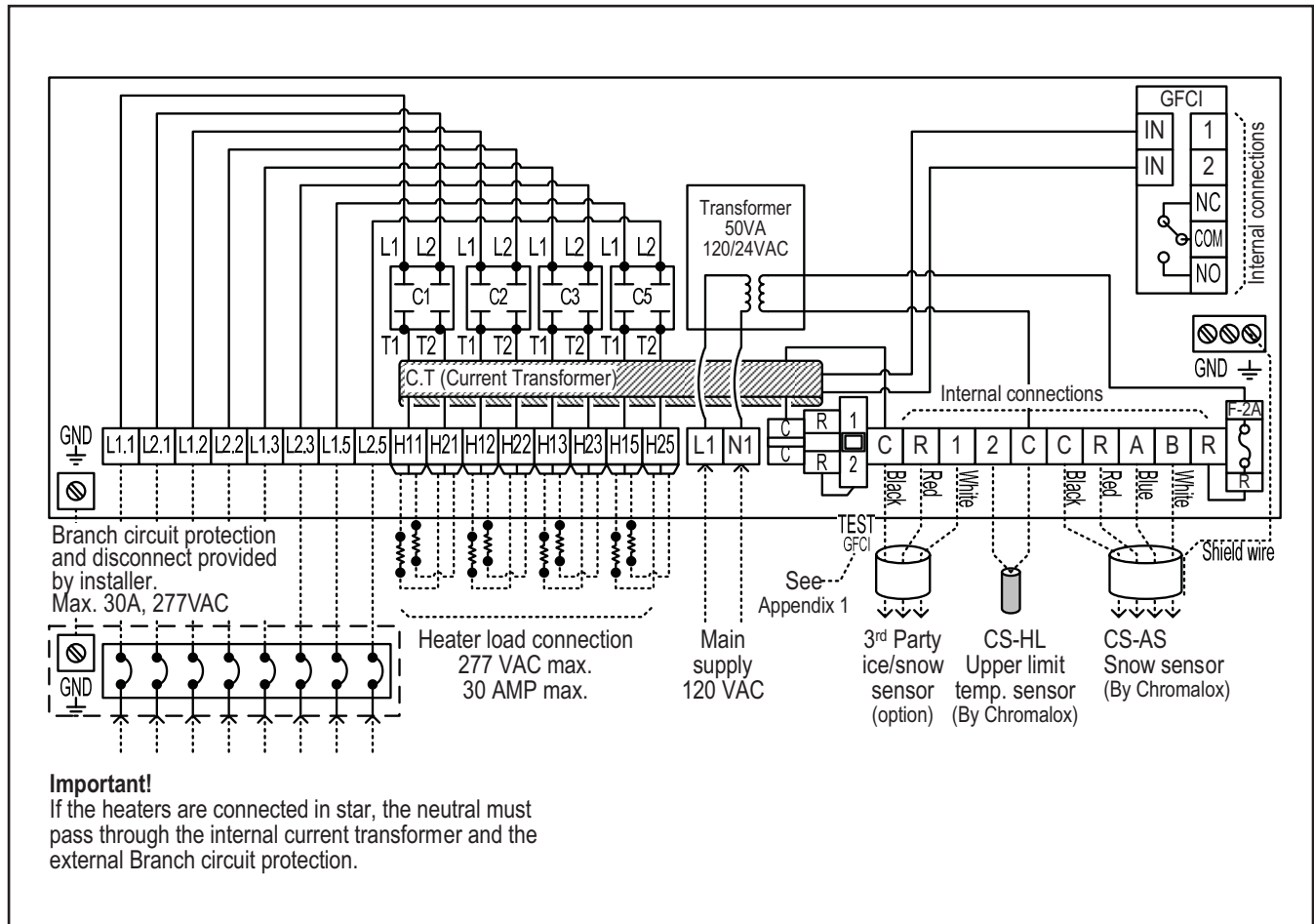

Wiring Options

Model	Supply	Loads	Notes	Drawing
ChromaMelt 3	1Px120V	120V,4x30A		1
	1Px240V	240V,4x30A		
ChromaMelt 3C	3Px208V	208V,2x50A + 208V,30A	Option 1: 1 heater per contactors C1, C2 and C5	2
	3Px347V	347V,2x50A		
	3Px480V	480V,2x50A		
	3Px600V	600V,2x50A		
	3Px208V	208V,6x50A	Option 2: 3 heaters per contactors C1-C2 (triangle) 1 heater per contactor C5	3
	3Px347V	347V,6x50A		
	3Px480V	480V,6x50A		
	3Px600V	600V,6x50A		
	3Px208V + N	208V,2x50A + 120V,30A	Option 1: 1 heater per contactors C1, C2 and C5 (Neutral connected to C5)	4
	3Px347V + N	347V,2x50A + 200V,30A		
	3Px480V + N	480V,2x50A + 277V,30A		
	3Px600V + N	600V,2x50A		
	3Px208V	208V,6x50A + 120V,30A	Option 2: 3 heaters per contactors C1-C2 (triangle) 1 heater per contactor C5	5
	3Px347V	347V,6x50A + 200V,30A		
	3Px480V	480V,6x50A + 277V,30A		
	3Px600V	600V,6x50A		
	3Px208V + N	120V,2x50A + 120V,30A	Option 3: 1 heater per contactors C1, C2 and C5 (Neutral connected to all contactors)	6
	3Px347V + N	200V,2x50A + 200V,30A		
3Px480V + N	277V,2x50A + 277V,30A			
3Px600V + N	347V,2x50A			
ChromaMelt 5	3Px208V	208V,4x50A + 208V,30A	Option 1: 1 heater per contactors C1-C5	7
	3Px347V	347V,4x50A		
	3Px480V	480V,4x50A		
	3Px600V	600V,4x50A		
	3Px208V	208V,12x50A + 208V,30A	Option 2: 3 heaters per contactors C1-C4 (triangle) 1 heater per contactor C5	8
	3Px347V	347V,12x50A		
	3Px480V	480V,12x50A		
	3Px600V	600V,12x50A		
	3Px208V + N	208V,4x50A + 120V,30A	Option 1: 1 heater per contactors C1-C5	9
	3Px347V + N	347V,4x50A + 200V,30A		
	3Px480V + N	480V,4x50A + 277V,30A		
	3Px600V + N	600V,4x50A		
	3Px208V + N	208V,12x50A + 120V,30A	Option 2: 3 heaters per contactors C1-C4 (triangle) 1 heater per contactor C5	10
	3Px347V + N	347V,12x50A + 200V,30A		
	3Px480V + N	480V,12x50A + 277V,30A		
	3Px600V + N	600V,12x50A		
	3Px208V + N	120V,4x50A + 120V,30A	Option 3: 1 heater per contactors C1-C5 (Neutral connected to all contactors)	11
	3Px347V + N	200V,4x50A + 200Vx30A		
3Px480V + N	277V,4x50A + 277V,30A			
3Px600V + N	347V,4x50A			

ChromaMelt 3

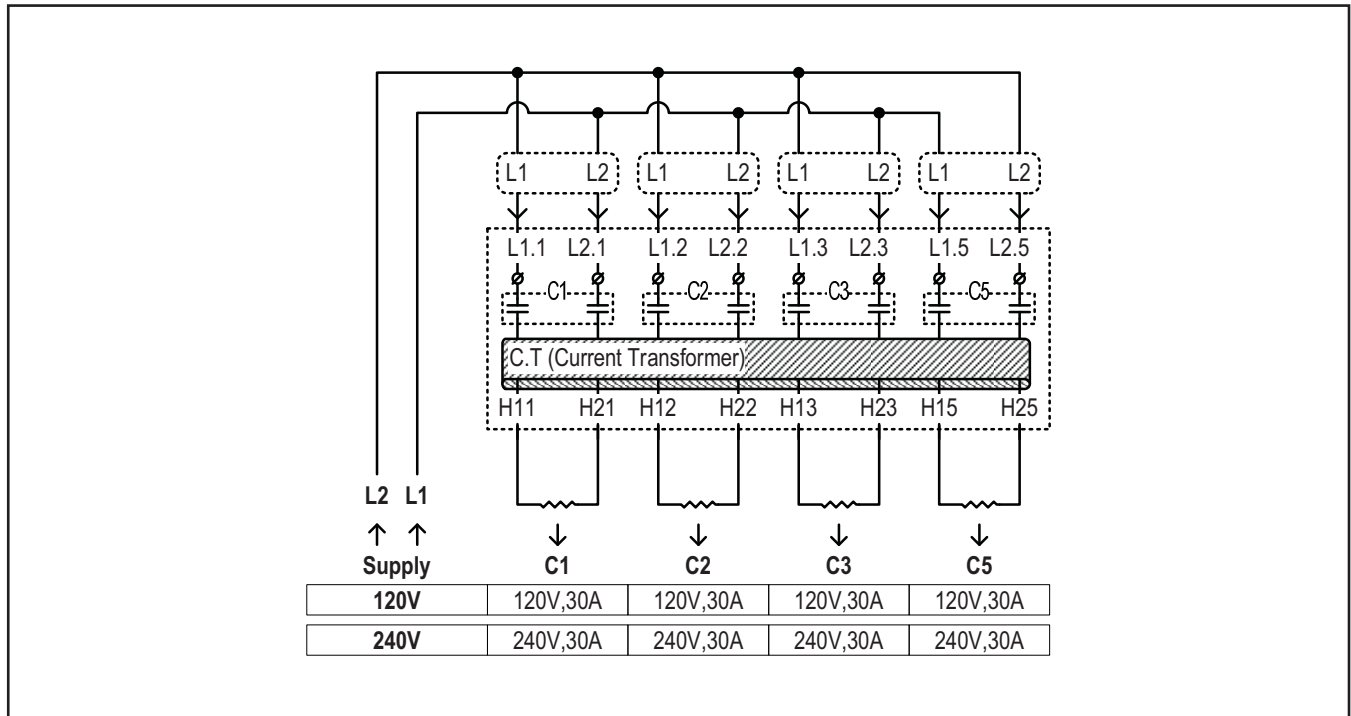

ChromaMelt 3C

Option 1: 1 heater per contactors C1, C2 and C5

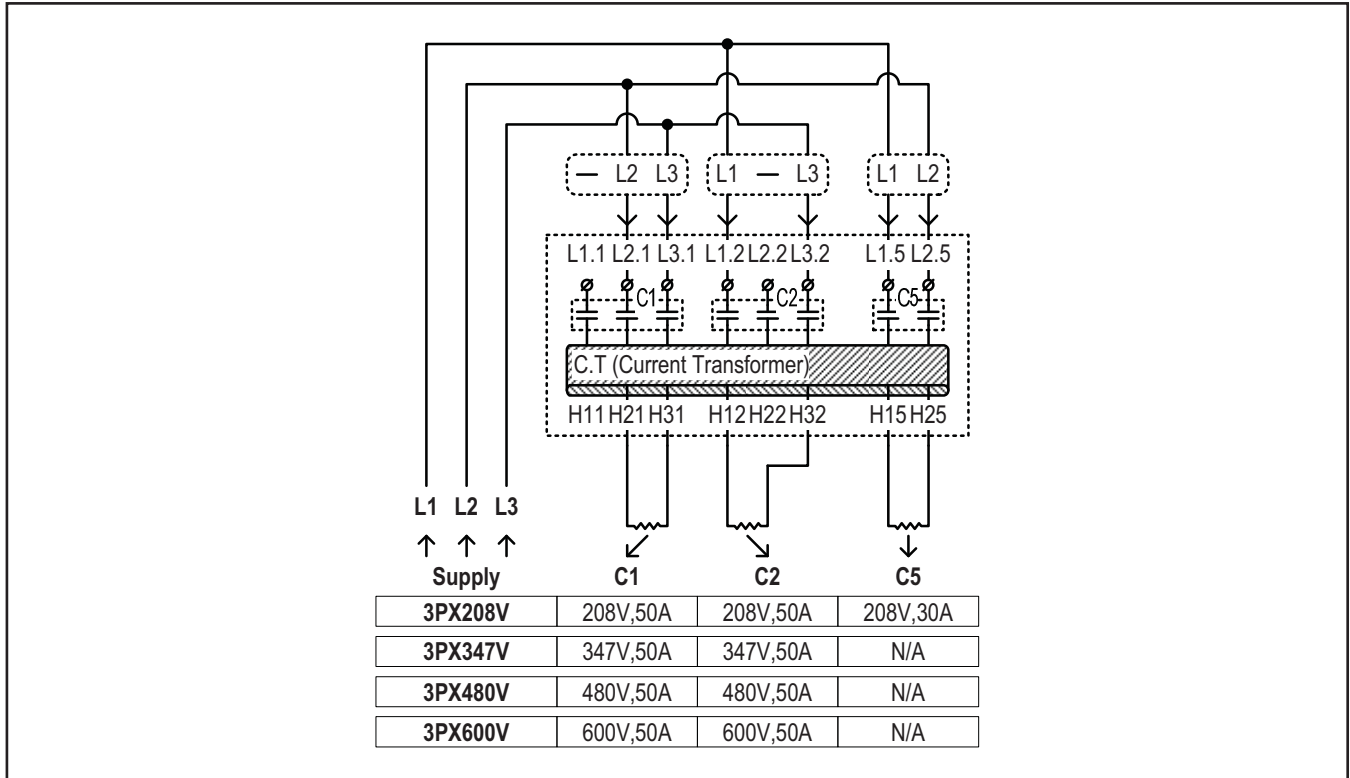

Option 2: 3 heaters per contactors C1 & C2 (triangle transform) & 1 heater per contactor C5

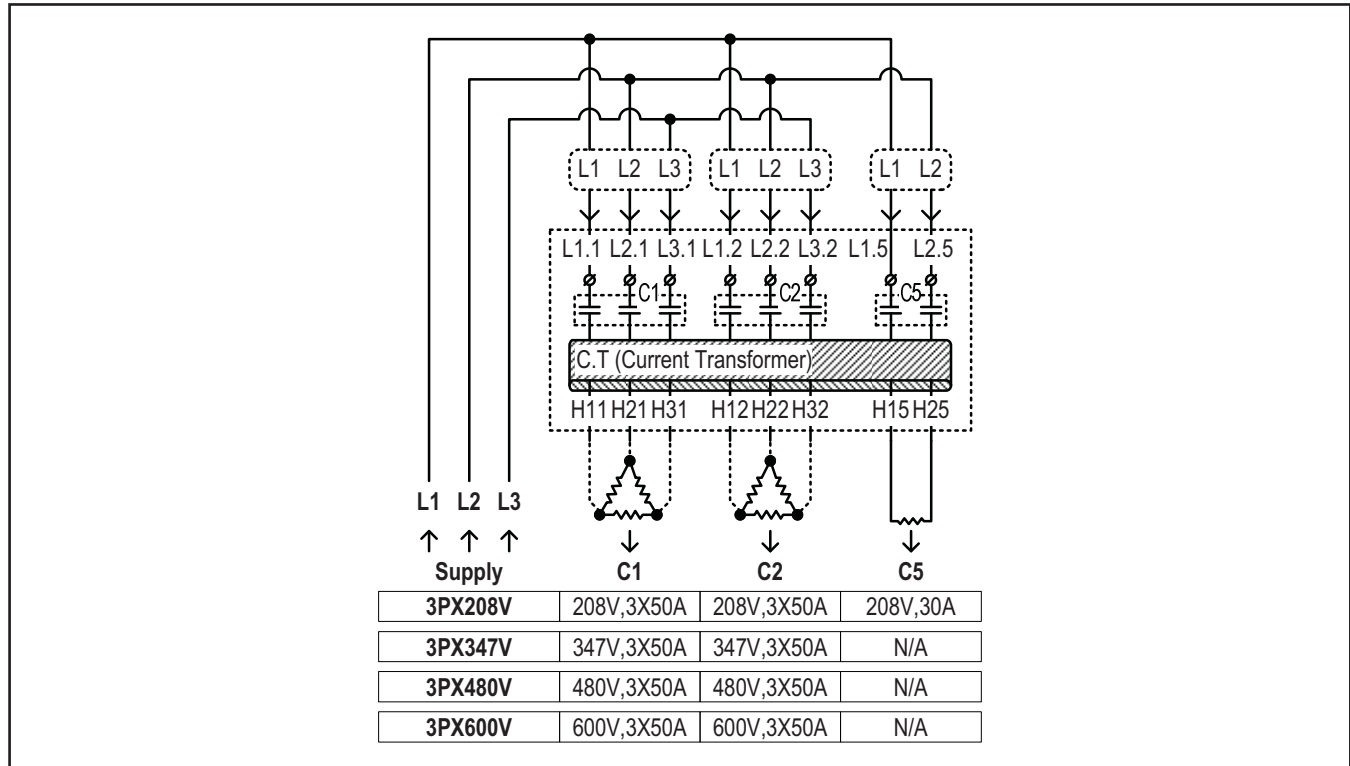

Note: Contactors 1 and 2 can be connected to any combination of 1 or 3 (triangle transform) heaters.

Example: Contactor C1 can be connected to 3 heaters (triangle transform) and contactor C2 can be connected to 1 heater.

ChromaMelt 3C – SUPPLY 3P with Neutral connected to C5

Option 1: 1 heater per contactors C1, C2 and C5 (Neutral connected to C5)

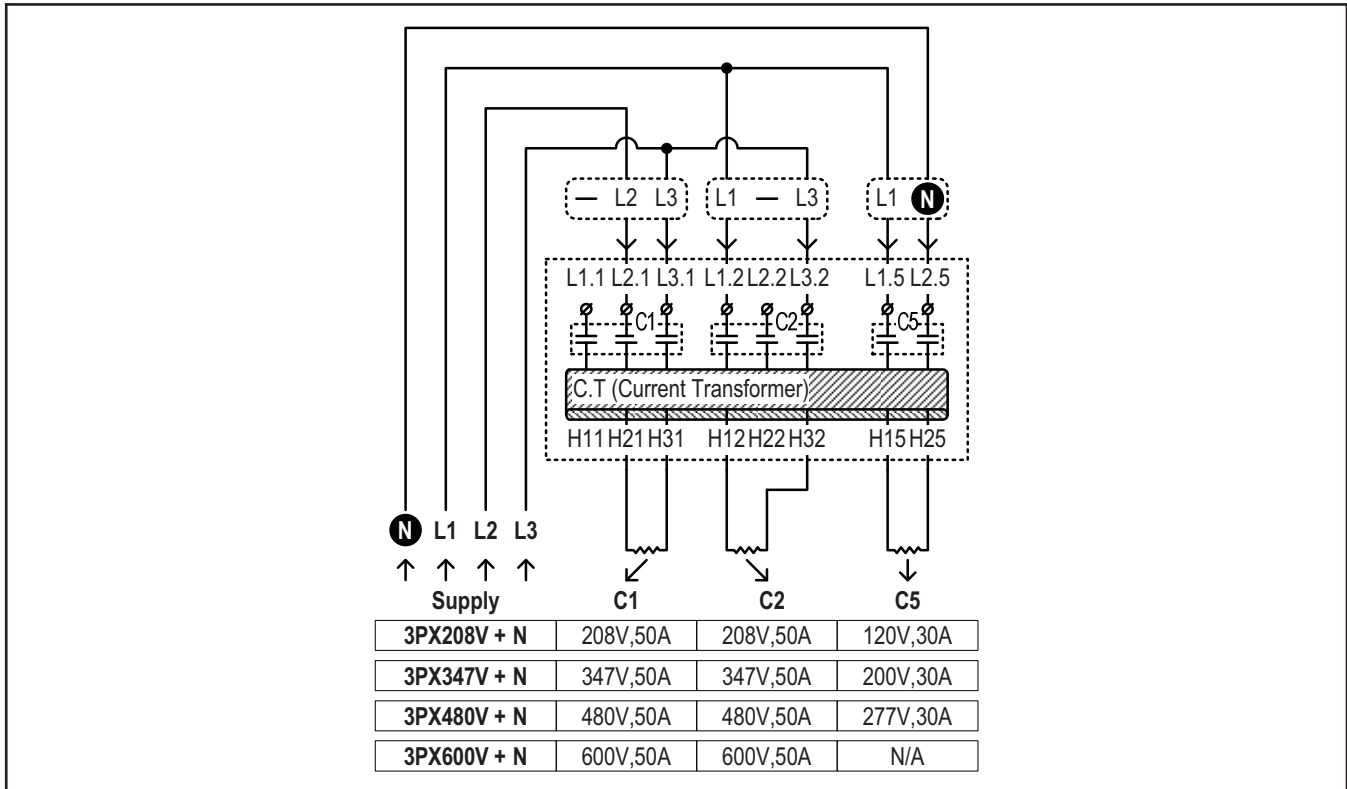

Option 2: 3 heaters per contactors C1 & C2 (triangle transform) & 1 heater per contactor C5

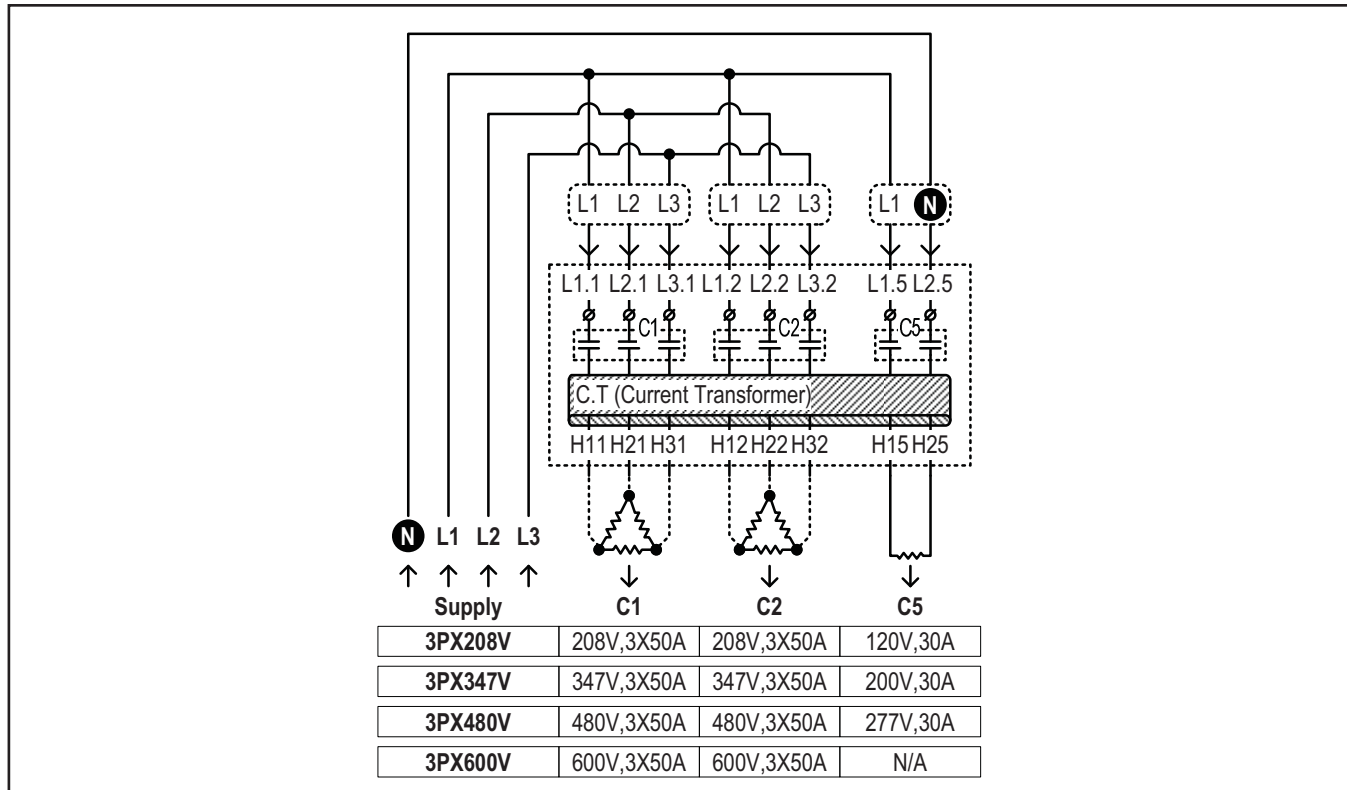

Note: Contactors 1 and 2 can be connected to any combination of 1 or 3 (triangle transform) heaters with and without Neutral.
Example: Contactor C1 connected to 3 heaters (triangle transform) and contactor C2 connected to 1 heater.

ChromaMelt 3C – SUPPLY 3P with Neutral connected to all contactors

Option 3: 1 heater per contactors C1, C2 and C5 (Neutral connected to C1, C2 and C5)

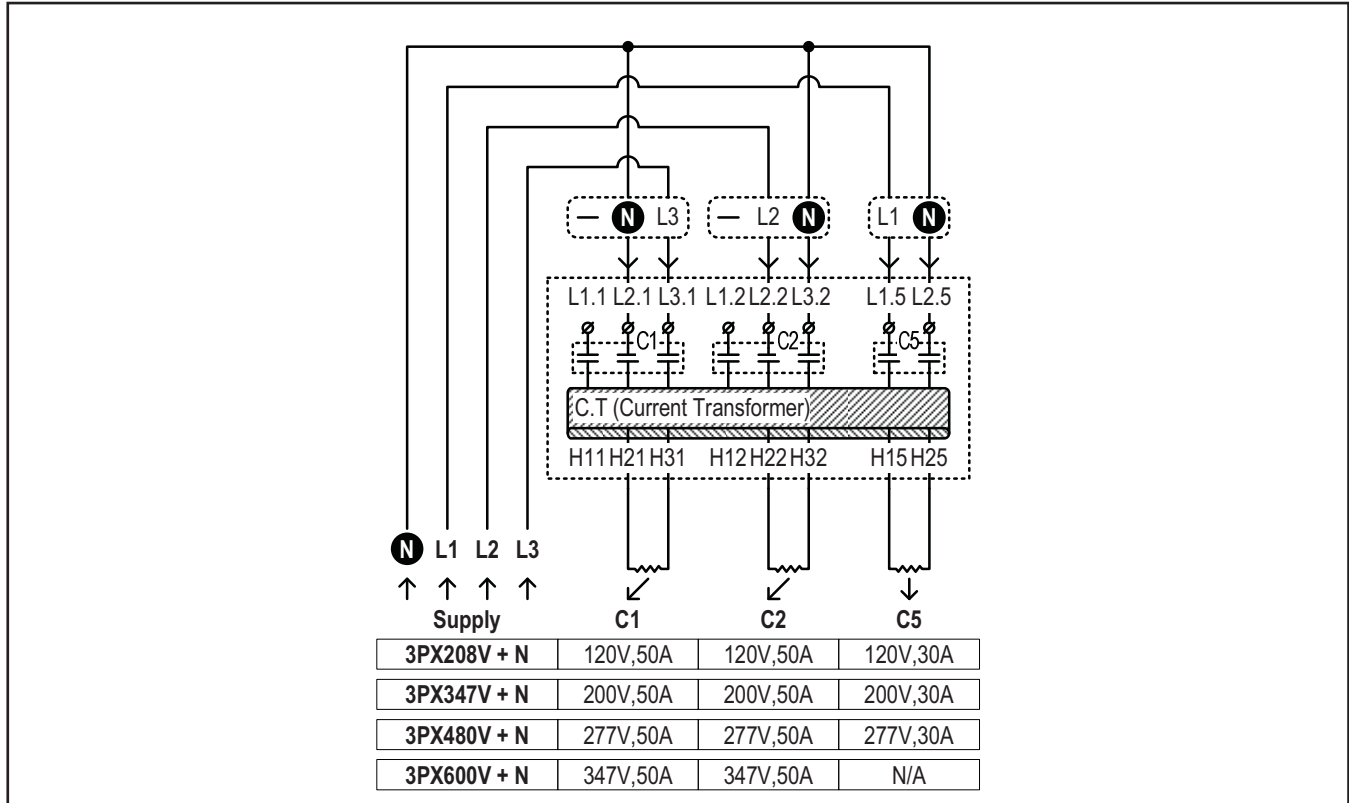

Note: Contactors 1 and 2 can be connected to any combination of 1 or 3 (triangle transform) heaters with and without Neutral.
Example: Contactor C1 connected to 3 heaters (triangle transform) and contactor C2 connected to 1 heater.

ChromaMelt 5 – SUPPLY 3P without Neutral

Option 1: 1 heater per contactors C1, C2, C3, C4 and C5

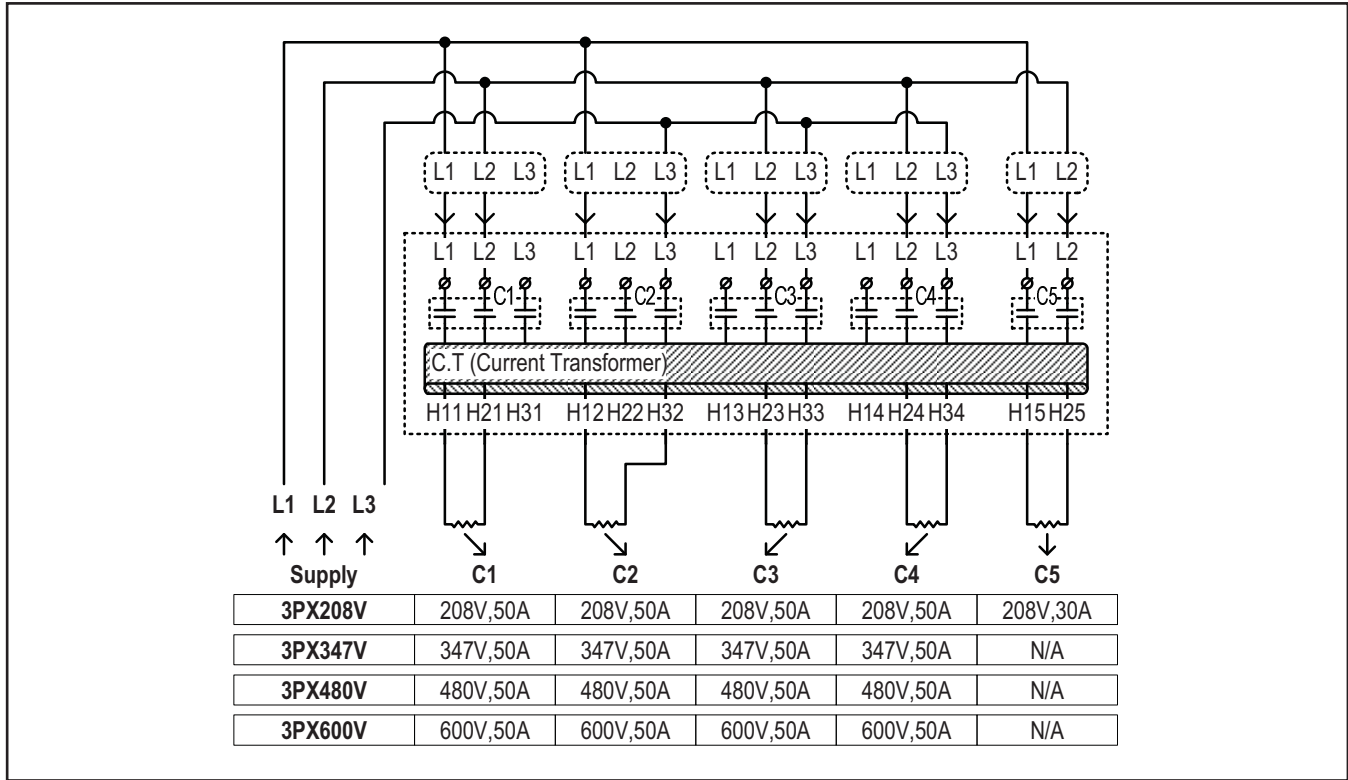

Option 2: 3 heaters per contactors C1, C2, C3 & C4 (triangle transform) & 1 heater per contactor C5

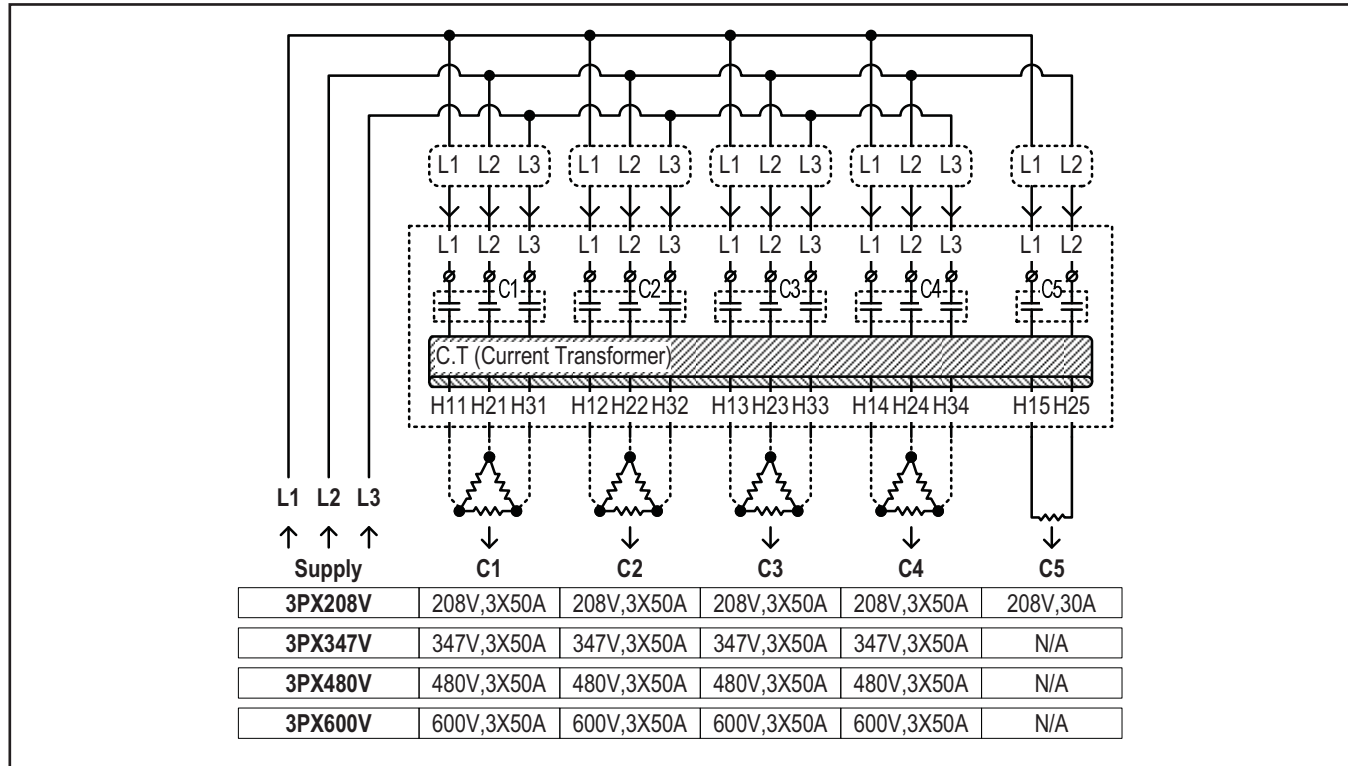

Note: Contactors 1 and 2 can be connected to any combination of 1 or 3 (triangle transform) heaters.

Example: Contactor C1 can be connected to 3 heaters (triangle transform) and contactor C2 can be connected to 1 heater.

ChromaMelt 5 – ChromaMelt 5 – SUPPLY 3P with Neutral connected to C5

Option 1: 1 heater per contactors C1, C2, C3, C4 and C5

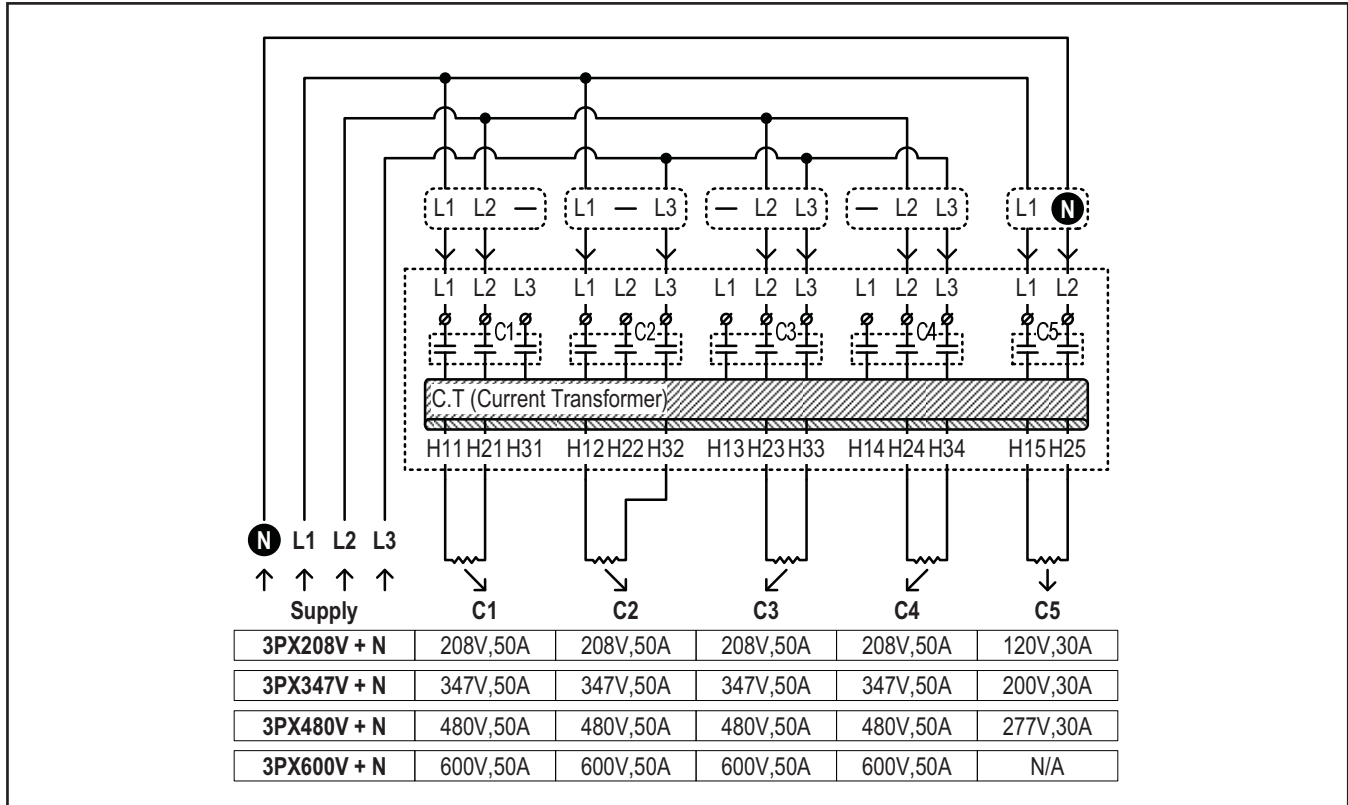

Option 2: 3 heaters per contactors C1, C2, C3 & C4 (triangle transform) & 1 heater per contactor C5

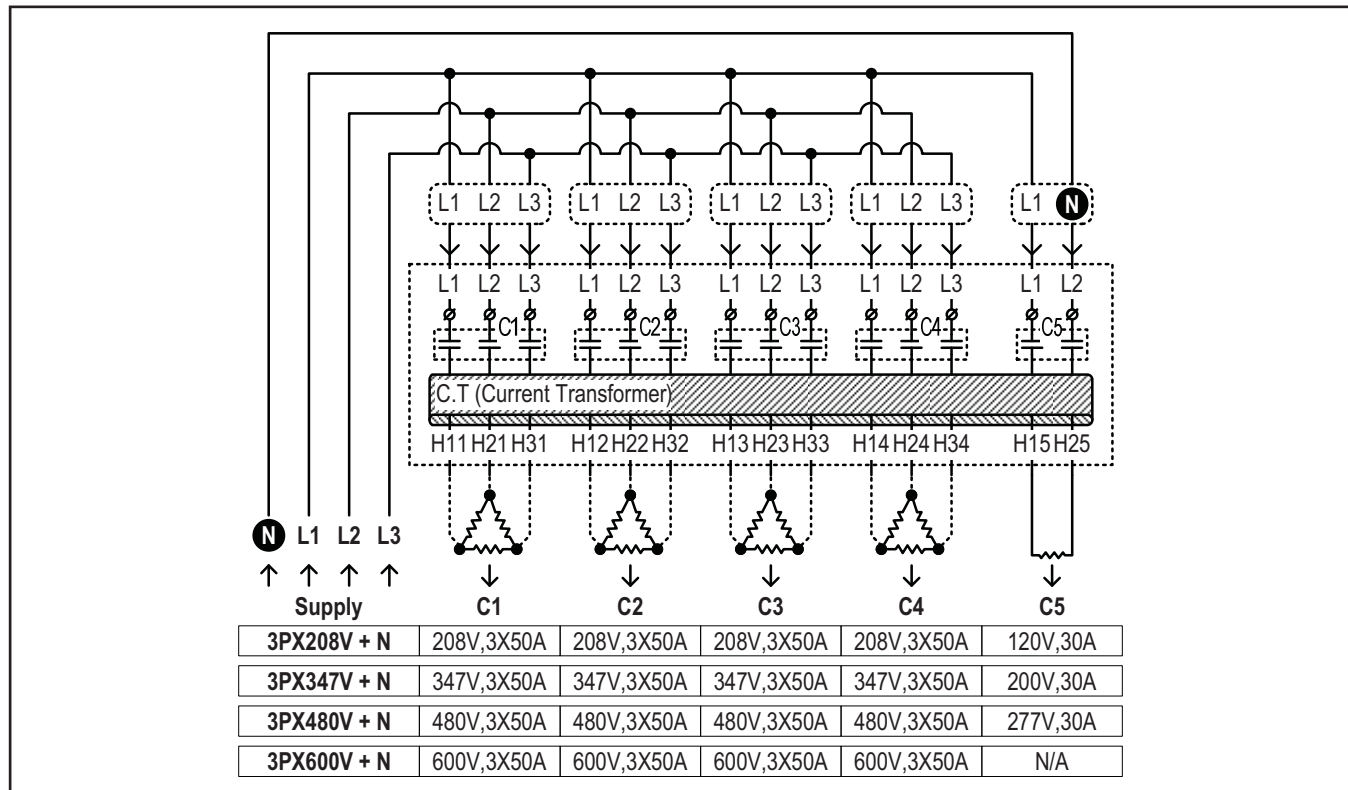

ChromaMelt 5 – SUPPLY 3P with Neutral connected to all contactors

Option 3: 1 heater per contactors C1, C2, C3 & C4 & C5
 (Neutral connected to C1, C2, C3, C4 and C5)

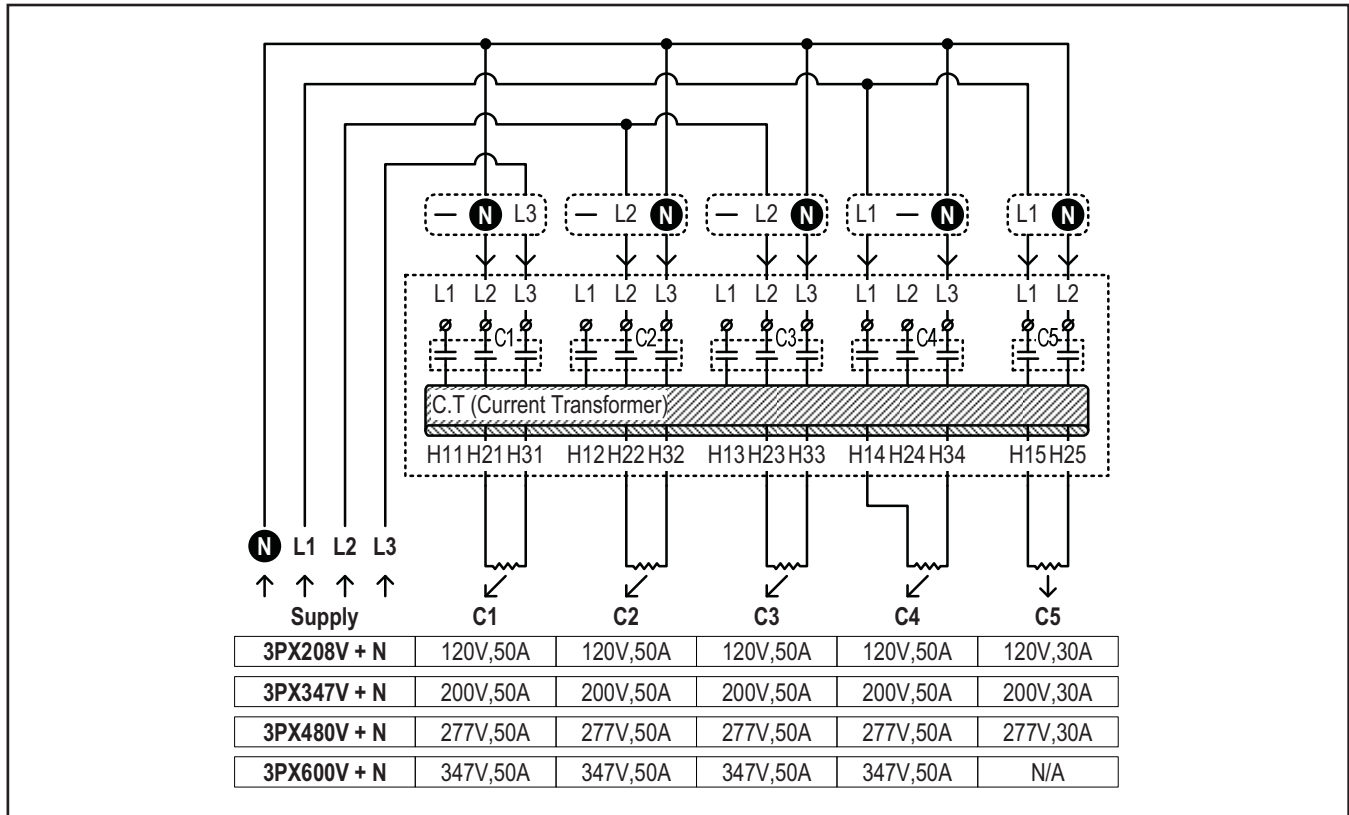

Note: Contactors 1,2,3 and 4 can be connected to any combination of 1 or 3 (triangle transform) heaters with and without Neutral.

Example: Contactor C1,C2 and C3 connected to 3 heaters (triangle transform) and contactor C2 connected to 1 heater.

Connecting snow sensors to the system

The system can be configured to operate with 1, 2, 3 or 4 snow sensors.

Each snow sensors must have different MAC address in order to communicate with the main board.

The CS-AS snow sensors series includes 4 different part numbers, each is factory pre-configured with unique MAC address as follows:

- CS-AS MAC Address 1
- CS-AS2 MAC Address 2
- CS-AS3 MAC Address 3
- CS-AS4 MAC Address 4

IMPORTANT! When connecting more than one sensor, snow sensor 1 must be connected last in communication line.

The snow sensors will control zones upon the following logic:

Number of sensors connected	Sensor #	Zones controlled by the sensor
1	1	1,2,3,4,5*
2	1	1,2
	2	3,4,5*
3	1	1
	2	2
	3	3,4,5*
4	1	1
	2	2
	3	3
	4	4,5*

*Zone 5 Optional

Notes:

- The number of snow sensors connected must be configured in section P09 of the technician settings.
- When one of the snow sensors cannot be viewed through communication (faulty or not connected), the values on snow sensor 1 will be used instead.

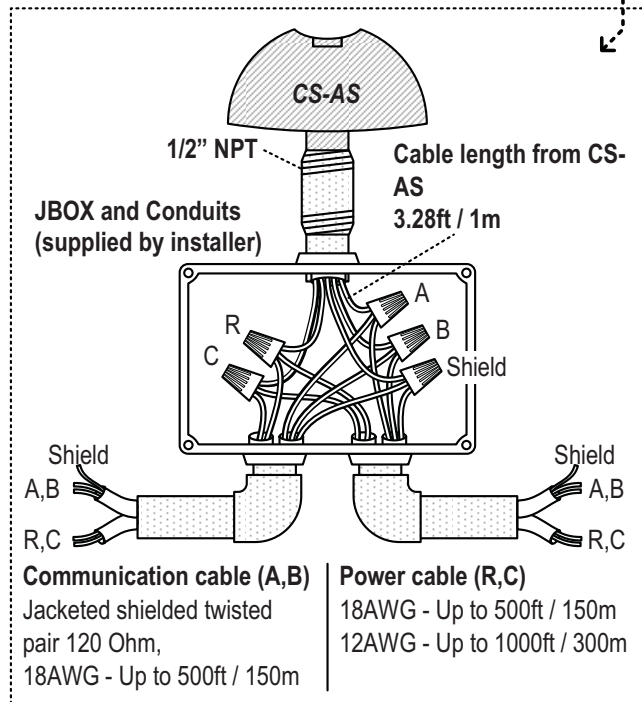
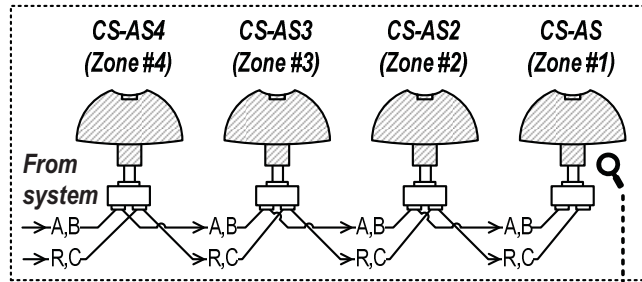

The CS-AS is supplied with:

1. A plastic cap, to protect the sensor from dust and debris for when the sensor is not in use (off season).

IMPORTANT! The protective cap must be removed before use of the sensor.

If the protective cap is not removed, the sensor will not detect snow!

2. Plastic spikes, to be used if necessary, to keep birds off the sensor.

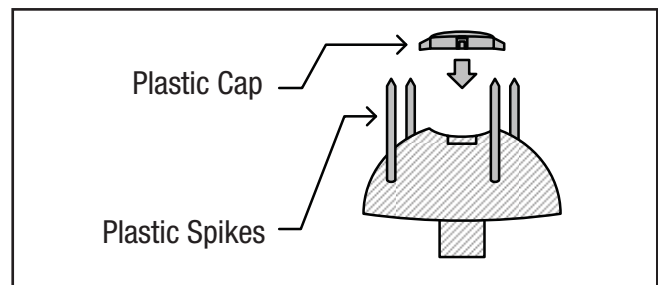

Operating Instructions

Green POWER lamp

The green power lamp will light when power is supplied to the unit (120 VAC)

Red GROUND FAULT RESET lamp and button

1. The red GROUND FAULT RESET lamp will lit when the internal GFCI is tripped.
2. Press and hold the GROUND FAULT RESET button for 5 seconds to reset the unit.

Turning the System ON and OFF

1. Press and hold the [ON] button for 0.5 seconds to turn the system ON or OFF.
2. The words "ON" or "OFF" will appear on display.

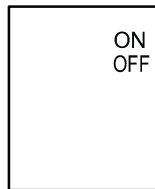

Selecting Temperature Scale

1. Press the [+] button for Celsius.
2. Press the [-] button for Fahrenheit.

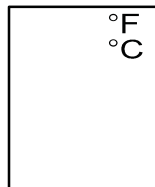

Selecting Automatic or Manual Mode

1. Press the [SELECT] button to switch between modes:

"Automatic" Heating will start and stop automatically depending on the set point and ambient temperatures.

"Manual ON" Heating will start regardless of the set point and ambient temperatures and will stop after a preset time (pls. refer to the "Manual ON" section in the tech. settings).

NOTE: Mode will always return to "Automatic" after switching the unit OFF and ON.

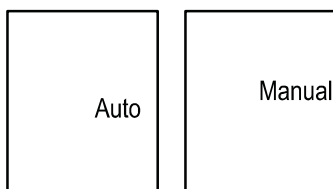

Heater Indication

The number beneath the heater icon indicates the heater stage (1 to 5).

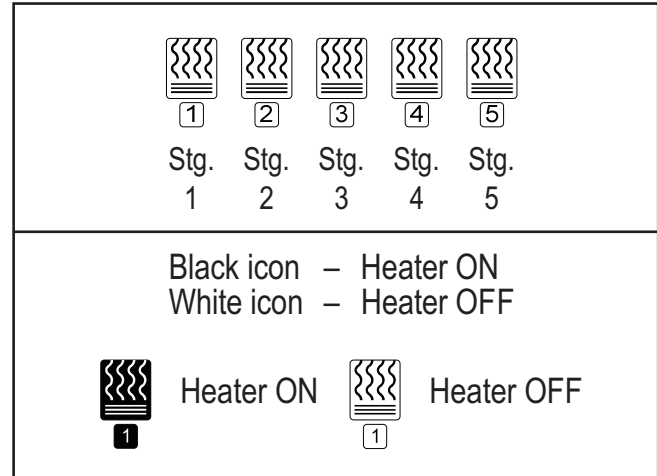

Snow Flake Icon and Digital Time Indication

A solid snow flake icon will appear on display while sensing snow and during normal heaters operation.

A blinking snow flake icon will appear on display during heaters off delay or when manual mode is activated. The digital clock will count down the remaining time until the heaters are turned off.

The snow flake icon will disappear from display as long as the heaters are turned off.



Technician Settings

Use the technician settings mode to view and adjust the following parameters:

P01	Temperature set point
P02	Lower ambient temperature limit to stop heater
P03	Energy saving, upper slab temperature limit to stop heaters
P04	Time delay before stopping the heaters
P05	ON time for manual mode
P06	Heaters cycle time / Splitting time

P07	Sensors and heaters control logic
P08	Snow sensor sensitivity
P88	Snow detection threshold
P09	Number of snow sensors connected
P10	Commissioning / Test mode
Restore defaults	

Enter Technician Settings Mode

1. Move DIP switch S1 located on the side of thermostat to ON position.
2. Press the [SELECT] and [+] buttons simultaneously to move forward to the next technician parameter.
3. Press the [SELECT] and [-] buttons simultaneously to return to the previous technician parameter.

Save Changes and Exit Technician Settings Mode

1. Move DIP switch S1 located on the side of thermostat to OFF position.

IMPORTANT: Changes made to technician parameters will not take effect as long as DIP switch S1 is in ON position.

Parameters:

P01 - Temperature set point

1. Move DIP switch S1 located on the side of thermostat to ON position.
2. "P01" and the temperature set point will appear on display.
3. Use the [+] and [-] buttons to adjust the temperature set point.
Range: 19...45°F / -7...+7°C

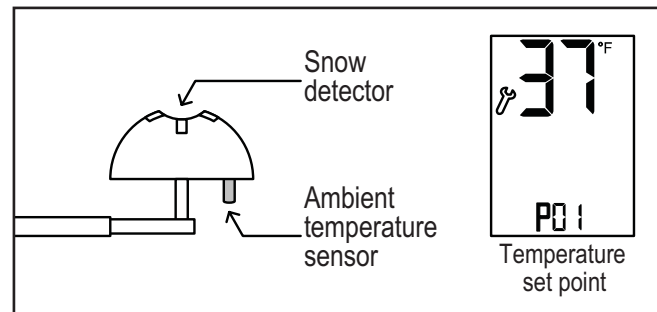

As long as the ambient temperature is lower than the temperature set point P01, the Controller will turn ON upon receiving a positive snow signal from the snow detector.

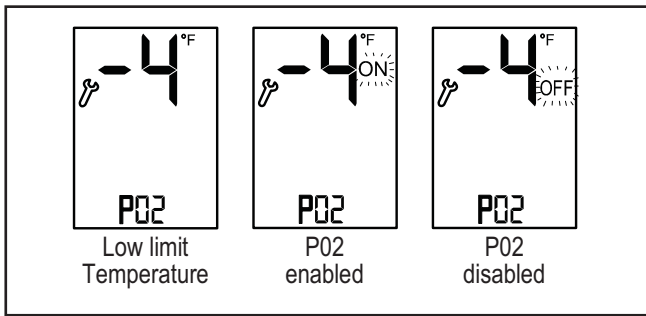
P02 - Lower limit temperature for heating

1. Press the [SELECT] and [+] buttons simultaneously.
2. "P02" and the low limit temperature will appear on display. When the temperature on the temperature sensor drops below the low temperature limit, the heating system will stop.
3. Use the [+] and [-] buttons to adjust the temperature set point.
Range: -4...+23°F / -20...-5°C Default: -4°F / -20°
4. Press the [SELECT] and [+] buttons simultaneously again.
5. The word "ON" or "OFF" will appear on display.
6. Use the [+] and [-] buttons enable (ON) or disable (OFF) the P02 parameter.
If disabled, the heating system will operate without low temperature limitations.

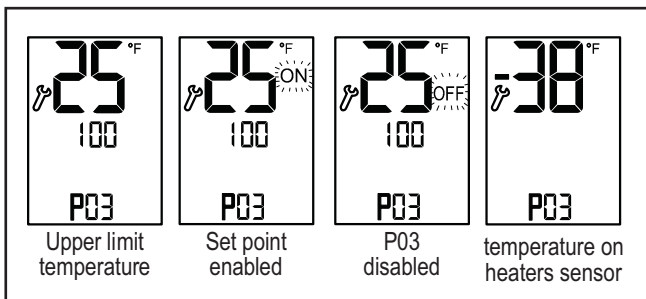
P03 – Upper limit temperature for heating

1. Press the [SELECT] and [+] buttons simultaneously.
2. "P03" and the slab upper limit temperature will appear on display.
3. Use the [+] and [-] buttons to adjust the upper limit temperature.
Range: +41...+125°F / +5...+52°C Default: 125°F / +52°C. *For numbers above 100, "100" will appear on display.
4. Press the [SELECT] and [+] buttons simultaneously again.
5. The word "ON" or "OFF" will appear on display.
6. Use the [+] and [-] buttons enable (ON) or disable (OFF) the P03 parameter.
If disabled, the heaters will work regardless of the upper limit.
7. Press the [SELECT] and [+] buttons simultaneously again.

8. The display will show the temperature on the upper limit sensor.

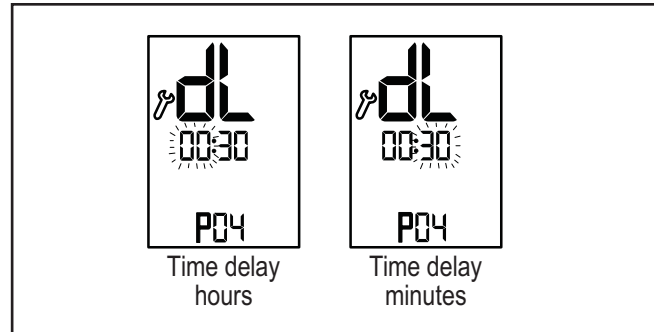
P04 - Manual mode ON time

1. Press the [SELECT] and [+] buttons simultaneously.
2. "P04", "dL" and the time delay before stopping the heaters (Hold ON) will appear on display. The hours will blink.
3. Use the [+] and [-] buttons to adjust the hours of the time delay.
Range: 00...99 hours Default: 00 hours
4. Press the [SELECT] and [+] buttons simultaneously again. The minutes will blink.
5. Use the [+] and [-] buttons to adjust the minutes of the time delay.
Range: 00...59 minutes Default: 30 minutes

Note 1. The time delay countdown will start when the snow detection signal from snow sensor will switch from positive to negative.

Note 2. The staggering sequence will continue during the time delay period.

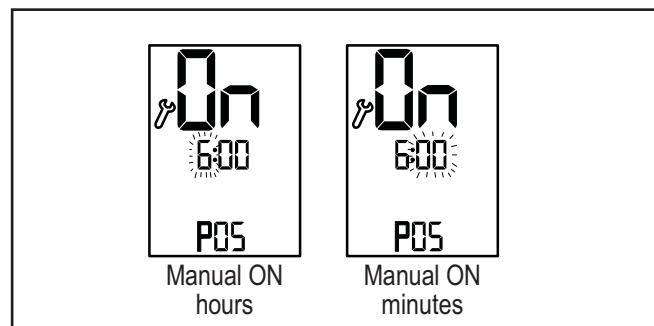
P05 -Manual mode ON time

1. Press the [SELECT] and [+] buttons simultaneously.
2. "P05", "On" and the "Manual ON" mode time period will appear on display. The hours will blink.
3. The delay time parameter defines a time frame in which the heaters remain ON after receiving an "Manual ON" command.
4. Use the [+] and [-] buttons to adjust the hours of the working time.
Range: 00...99 hours Default: 6 hours
5. Press the [SELECT] and [+] buttons simultaneously again. The minutes will blink.

- Use the [+] and [-] buttons to adjust the minutes of the working time.
Range: 00...59 minutes Default: 00 minutes

P06 – Heaters cycle and splitting time

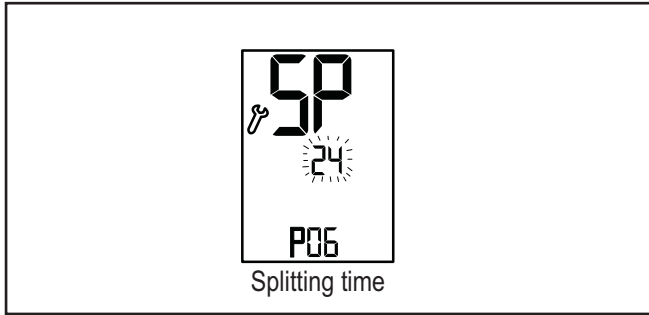

- Press the [SELECT] and [+] buttons simultaneously.
- “P06”, “SP” and the splitting time will appear on display. The minutes will blink.
- The heaters cycle / splitting time parameter defines the working time of the heaters when working in sequence.

Example: the splitting time is set to 10 minutes and 4 heaters work in sequence, each heater will be ON for 2.5 minutes (10/4=2.5).

- Use the [+] and [-] buttons to adjust the splitting time.
Range: 10...1999 minutes Default: 24 minutes.

P07 – Heaters outputs logic controlled by CS-AS snow melt sensor or by 3rd party sensor

- Press the [SELECT] and [+] buttons simultaneously.
- “P07” and the figures “0”, “1”, “2” or “3” will appear on display.
- Use the [+] and [-] buttons to define the heaters logic (model dependent) as follows:

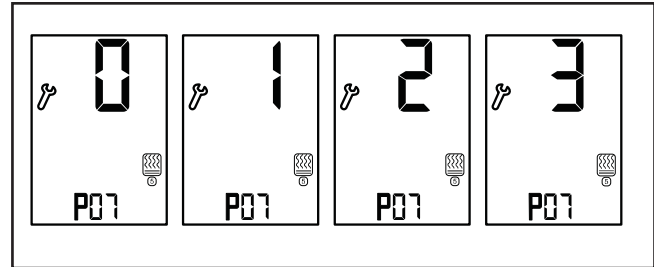

ChromaMelt 3 Outputs 1,2,3 and 5

Value	Output Controlled by CS-AS	Outputs controlled by 3rd Party Sensor	Comments
0	All Outputs	–	Default
1	1,2,3	5	
2	–	All Outputs	The display will not show the ambient temperature and will remain blank.
3	1,2,3,5		Snow on any of the sensors will trigger all zones

ChromaMelt 3C Outputs 1,2 and 5

Value	Output Controlled by CS-AS	Outputs controlled by 3rd Party Sensor	Comments
0	All Outputs	–	Default
1	1,2	5	
2	–	All Outputs	The display will not show the ambient temperature and will remain blank.
3	1,2,5		Snow on any of the sensors will trigger all zones

ChromaMelt 5 Outputs 1,2,3,4 and 5

Value	Output Controlled by CS-AS	Outputs controlled by 3rd Party Sensor	Comments
0	All Outputs	–	Default
1	1,2,3,4	5	
2	–	All Outputs	The display will not show the ambient temperature and will remain blank.
3	1,2,3,4,5		Snow on any of the sensors will trigger all zones

Note: 3rd party sensors - i.e. gutter or pavement sensors – CIT, GIT, SIT by eti.

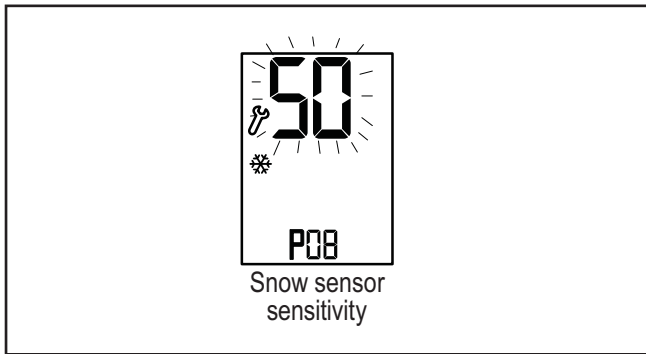
P08 - Snow sensor sensitivity

1. Press the [SELECT] and [+] buttons simultaneously
2. "P08" and the snow sensor sensitivity value will appear on display.
3. Use the [+] and [-] buttons to adjust the sensitivity. Range: 20...80 % (20% - Less sensitive, 80% - more sensitive), Default: 50 %

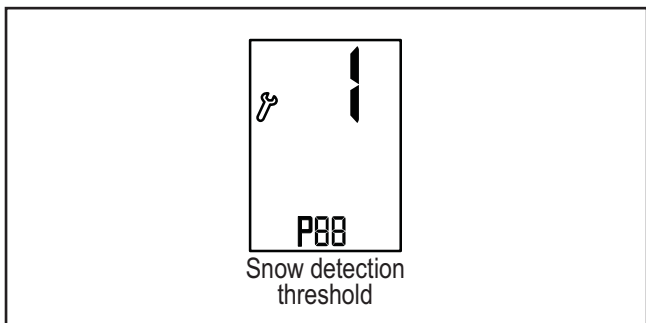
P88 - Snow detection threshold

1. Press the [SELECT] and [+] buttons simultaneously.
2. "P88" and the snow sensor threshold will appear on display.
3. Use the [+] and [-] buttons to adjust the threshold. Range: 00...60 minutes Default: 5 minutes

If the threshold is not reached, the logic of turning the heaters either ON or OFF will not be affected by snow detection.

During countdown to threshold time, the snow flake icon will flash.

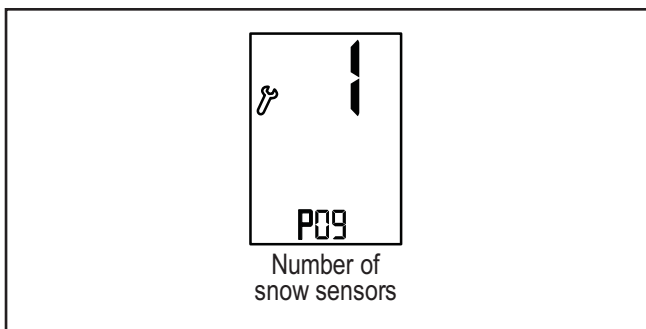
P09 - Test conditions mode / Technician commissioning mode

Turn ON test conditions to check the functionality of the system regardless of temperature sensors parameters (i.e. during the summer).

In test conditions, the Ambient temperature is always -7°C/19°F.

1. Press the [SELECT] and [+] buttons simultaneously.
2. "P09" will appear on display. The hours will blink.
3. Use the [+] button to enter test/commissioning mode – the word "Test" will appear on display.
4. Use the [-] button to manually exit test/commissioning mode – the word "Test" will disappear from display.

Note: If the technician did not manually exit test/commissioning mode, the unit will automatically return to normal mode after 5 hours.

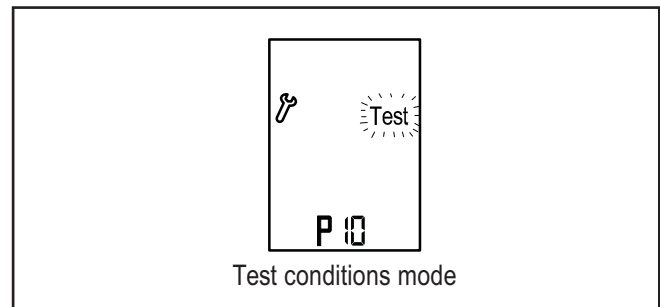
P10 - Test conditions mode / Technician commissioning mode

Turn ON test conditions to check the functionality of the system regardless of sensors parameters (i.e. during the summer).

In test conditions, the Ambient temperature is always -5°C/23°F.

Note: In order to trigger the system and activate the heaters, use some water to wet the circuit on top of the snow sensor.

1. Press the [SELECT] and [+] buttons simultaneously.
2. "P10" will appear on display. The hours will blink.
3. Use the [+] button to enter test/commissioning mode – "Test" will appear on display.
4. Use the [-] button to manually exit test/commissioning mode – "Test" will disappear from display.

Note: If the technician did not manually exit test/commissioning mode, the unit will automatically return to normal mode after 5 hours.

In order to save changes and return to normal display, move DIP switch S1 back to OFF position.

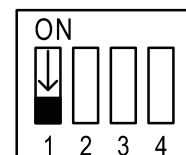

Save changes and return to normal display

Restore Default Values

IMPORTANT: Make sure the unit is turned OFF (the word "OFF" should appear on display).

1. Move DIP switch S1 to ON position.
2. Press and hold the [ON] button for 10 seconds. The thermostat will beep.
3. Move DIP switch S1 back to OFF position.

Enable/Disable Zones

1. Turn the unit OFF.
2. While OFF, Press both the [+] and [-] buttons simultaneously for 10 seconds.
3. Press the [Select] button to select zone. Selected zone will flash.
Press the [+] and [-] buttons enable/disable the selected zone.
Black icon and "ON" on LCD - Enabled zone.
White icon and "OFF" on LCD - Disable zone.
4. Press and hold the [+] and [-] buttons simultaneously for 5 seconds to exit.

Note: Disabled zones will be ignored in splitting time calculations:

Example: the splitting time is set to 60 minutes and heaters are set work in sequence.

3 Heaters enabled and 1 heater disabled.

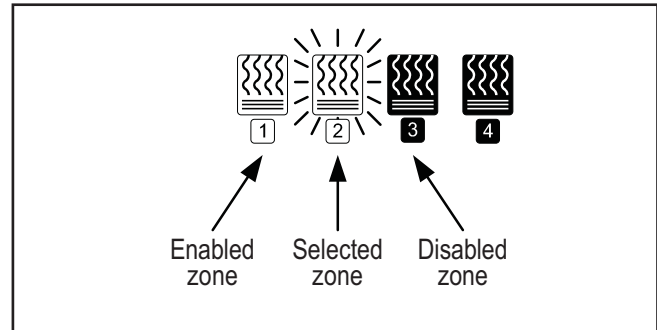

With all heaters enabled: Each heater will be ON for 15 minutes ($60/4=15$).

With 3 heaters enabled and 1 heater disabled: Each heater will be ON for 20 minutes ($60/3=20$).

DIP Switch Settings

DIP switch S2 - Short measuring times (test only)

Use DIP switch S2 to short the measuring times as follows:

- "ON" - Short measuring times – for test/commissioning only (measuring times will be divided to 60).
- "OFF" - Normal operation.

Short measuring times:

A real 1 hour will take 1 minute and a real 1 minute will take 1 second.

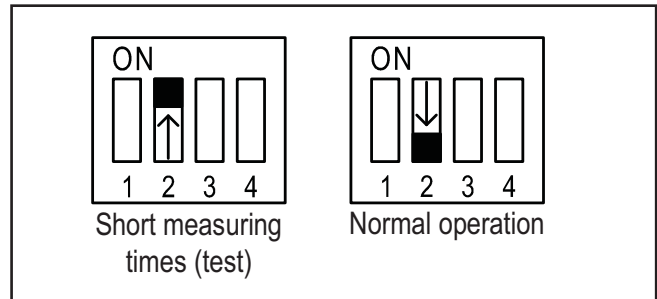

DIP switches S3 and S4 – heaters sequencing logic

Use DIP switches S3 and S4 to define the sequencing logic of the heater (zones) as follows:

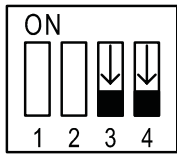

S3 OFF, S4 OFF

All 4 outputs work per request from the snow sensor(s)

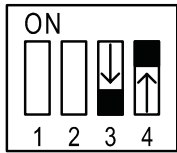
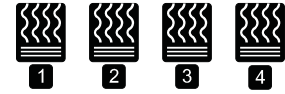

S3 OFF, S4 ON

Outputs 1+3 and outputs 2+4 work together (according to splitting time)

Note: Do not use this configuration with more than two snow sensors connected.

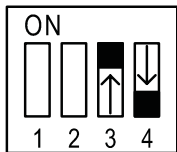
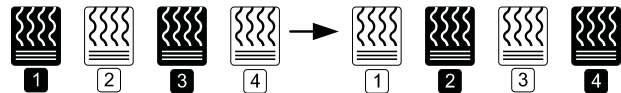

S3 ON, S4 OFF

Outputs 1,2 and 3 work in sequence (according to splitting time) and output 4 works continuously.

Note: Do not use this configuration with more than two snow sensors connected.

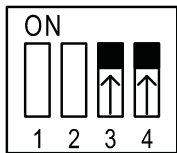
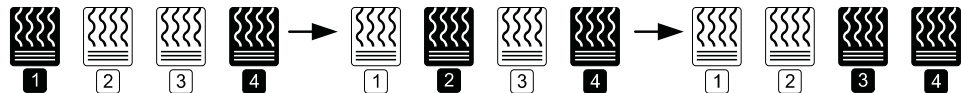

S3 ON, S4 ON

All 4 outputs work in sequence (according to splitting time)

Note: Do not use this configuration with more than two snow sensors connected.

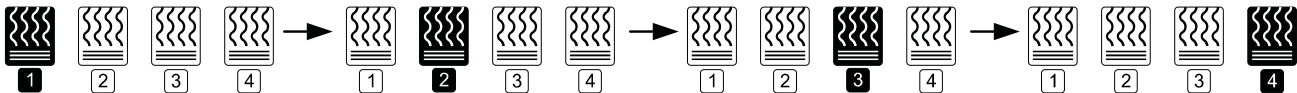

Notes:

1. The illustrations above show the heaters operation for the ChromaMelt 5. The logic remains the same for ChromaMelt 3C, without heaters 3 and 4, and for ChromaMelt 3, without heater 4.
2. Heater 5 for all models, will be activated with or without heater 4, depending on the “Heaters output logic” parameter set in section P07.
3. The logic will ignore disabled zones.

Temperature Reading Errors

Ambient temperature sensor readings (on snow sensor) are out of reliable measuring range

Ambient temperature < -9°F/-23°C

Ambient temperature > 54°F/12°C

The system will continue to operate using constant predefined values.

In addition, the display will alternate between “LO” and -11°F/-24°C

for low temperature readings, and between “HI” and 55°F/13°C for high temperature readings

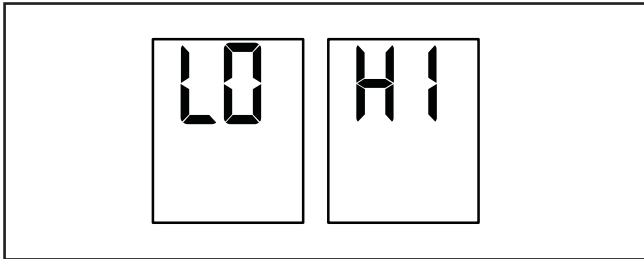

Error 2 – Upper limit temperature sensor is not connected or short circuit

“SensErr 2” Will appear on display.

The system will continue to operate regardless of the upper limit temperature.

Required actions:

1. Refer to P03 section of the technician settings.
2. Check the temperature value and disable the sensor if needed.
3. Replace the sensor.

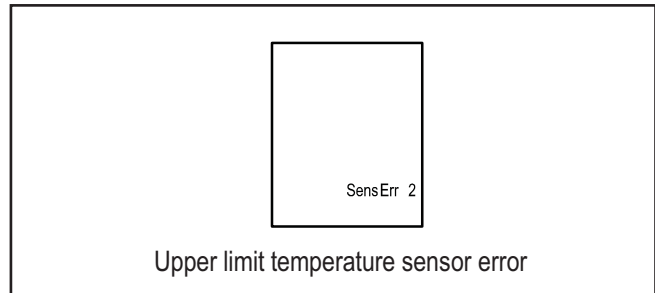

Error 1 – Communication error with one (or more) snow sensors

“SensErr 1” Will appear on display.

If the system is configured to work with more than 1 snow sensor, the faulty

snow sensor number will appear on display: P01, P02, P03 or P04.

The system will use readings from snow sensor 1 instead of the missing readings from the faulty snow sensor.

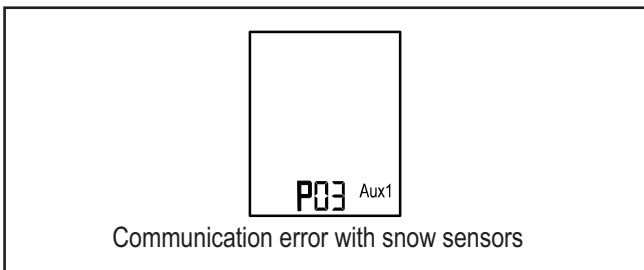

Appendix 1

Calibrating and testing the internal GFCI

The GFCI (ground fault circuit interrupter) is designed to provide protection for electrical equipment. The “ON” Time Delay and Current Trip should be configured to match application requirements.

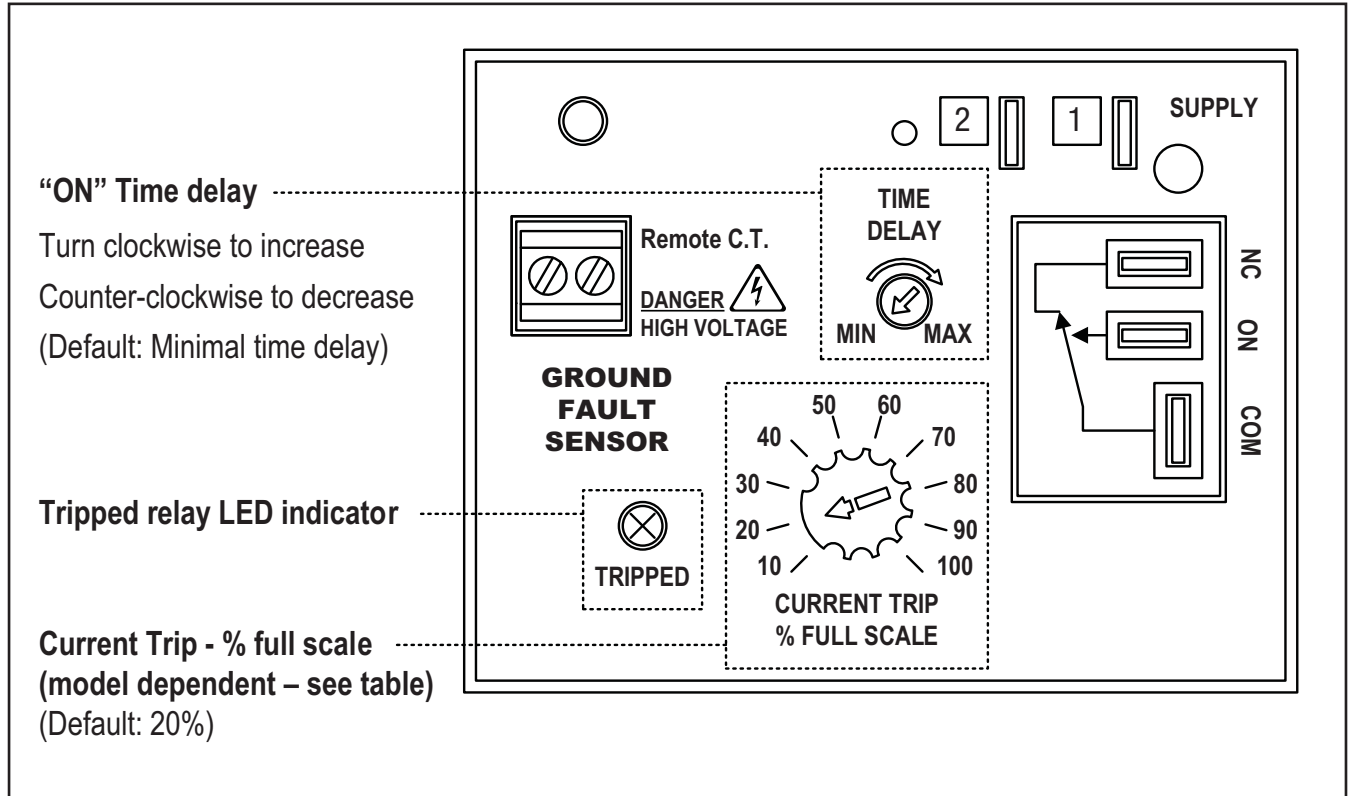

Indicator %	Current Trip (Amps)		GFCI Test
	ChromaMelt 5	ChromaMelt 3/3C	
10	0.1	0.01	The GFCI should be tested monthly. Press the red GFCI TEST button located next to the R,C terminals inside the box for 3 seconds to trip the outlet and break the circuit. The RED internal LED on the GFCI and the RED external lamp on the box door should lit. Press the RESET GFCI button on the box door for 5 seconds to return to normal operation and reestablish power and protection.
20	0.2	0.02	
30	0.3	0.03	
40	0.4	0.04	
50	0.5	0.05	
60	0.6	0.06	
70	0.7	0.07	
80	0.8	0.08	
90	0.9	0.09	
100	1.0	0.10	

Limited Warranty:

Please refer to the Chromalox limited warranty applicable to this product at
<http://www.chromalox.com/customer-service/policies/termsofsale.aspx>.

**Chromalox, Inc.
1347 Heil Quaker Boulevard
Laverne, TN 37086
(615) 793-3900
www.chromalox.com**

© 2021 Chromalox, Inc.