

THERMWIRE

ChromaMelt-2R Snow Sensor and Controller

- Load Switching (2 X 24A Relays)
- Adjustable Temperature Settings (C & F)
- Variable Delay Time (Hold ON and OFF Time)
- User Friendly Programming and Setting
- Adjustment Using Remote Control with Large LCD Display
- Adjustable Cycle Time between Zones while Staggering
- 2 Zones of Control - Operating Together or Staggering
- Easy and Simple 6 Wire Installation
- Logical and Remote Access for Installers During Set-up, Commissioning & Service
- Non Obtrusive Adjustable Snow Sensor Wall Bracket
- Automatic/Manual/Off Mode Selection by Switch or by Remote Control
- 4 Vertical Spikes to Prevent Birds Nesting
- RoHS



Description

The ChromaMelt-2R is a "Plug and Play" controller/sensor for snow melting applications. When the temperature drops below the adjustable set-point and moisture is present, it energizes the heating elements.

The Technician mode allows installers or technicians to adjust the parameters for customized installations using the electronic controller installed in the front panel. The adjustable Hold-On timer, keeps the outputs to the heaters active to ensure complete freeze protection.

The Hold-On (Time delay) is adjustable from 0 to 99 hours. The 4 vertical spikes prevent birds from nesting on top of the ChromaMelt-2R and blocking the sensing grid.

Specifications

ChromaMelt-2R Snow Sensor Controller

Indoor Temperature Sensor	14°F to 50°F (-10° C to 10°C)
Power Switching	Mechanical
Number of Circuits	2
Amp Rating/Circuit	24A
Input Voltage	110 - 240 VAC
Heater Voltage	110 - 240 VAC
Adjustable Parameters	Set-Point, Lower Limit Temperature, Hold-On Delay, Manual On time, Heater Cycle Time, Sequence Operation, Number of Zones, Commissioning/Test Mode

ChromaMelt-2R Accessories

CS-MB - Mounting bracket for ChromaMelt-2R



CS-RC - Remote control, operations and technical settings interface



CS-IR - Indoor control interface unit



CS-EC - 30' (10m) Extension Cable assembly for CS-IR



THERMWIRE

ChromaMelt-2R

Snow Sensor and Controller *(cont'd.)*

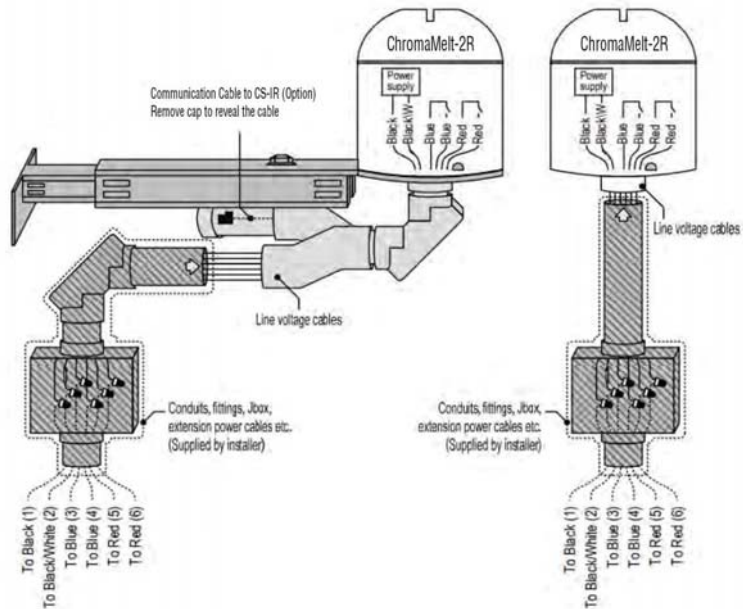

Dimensions

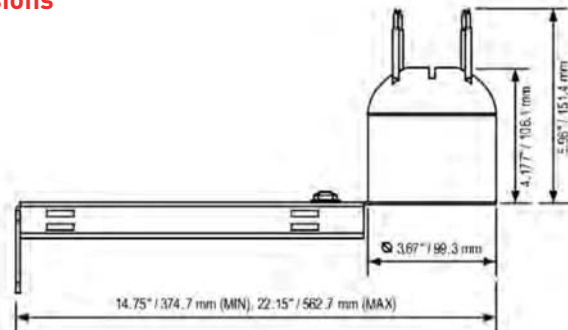

Ordering Information

Model	Description	PCN
ChromaMelt-2R	Snow sensor/controller for snow and ice melting (2 X 24A)	515311
ChromaMelt-2RK	ChromaMelt-2R, CS-MB, CS-RC, and CS-IR	515320
CS-MB	Wall mounted adjustable bracket for ChromaMelt-2R	514597
CS-RC	Remote control for changing operation and setting	514600
CS-IR	Indoor mounted control interface unit for ChromaMelt-2R	514618
CS-EC	Extension cable for CS-IR connection to the ChromaMelt-2R	514626